

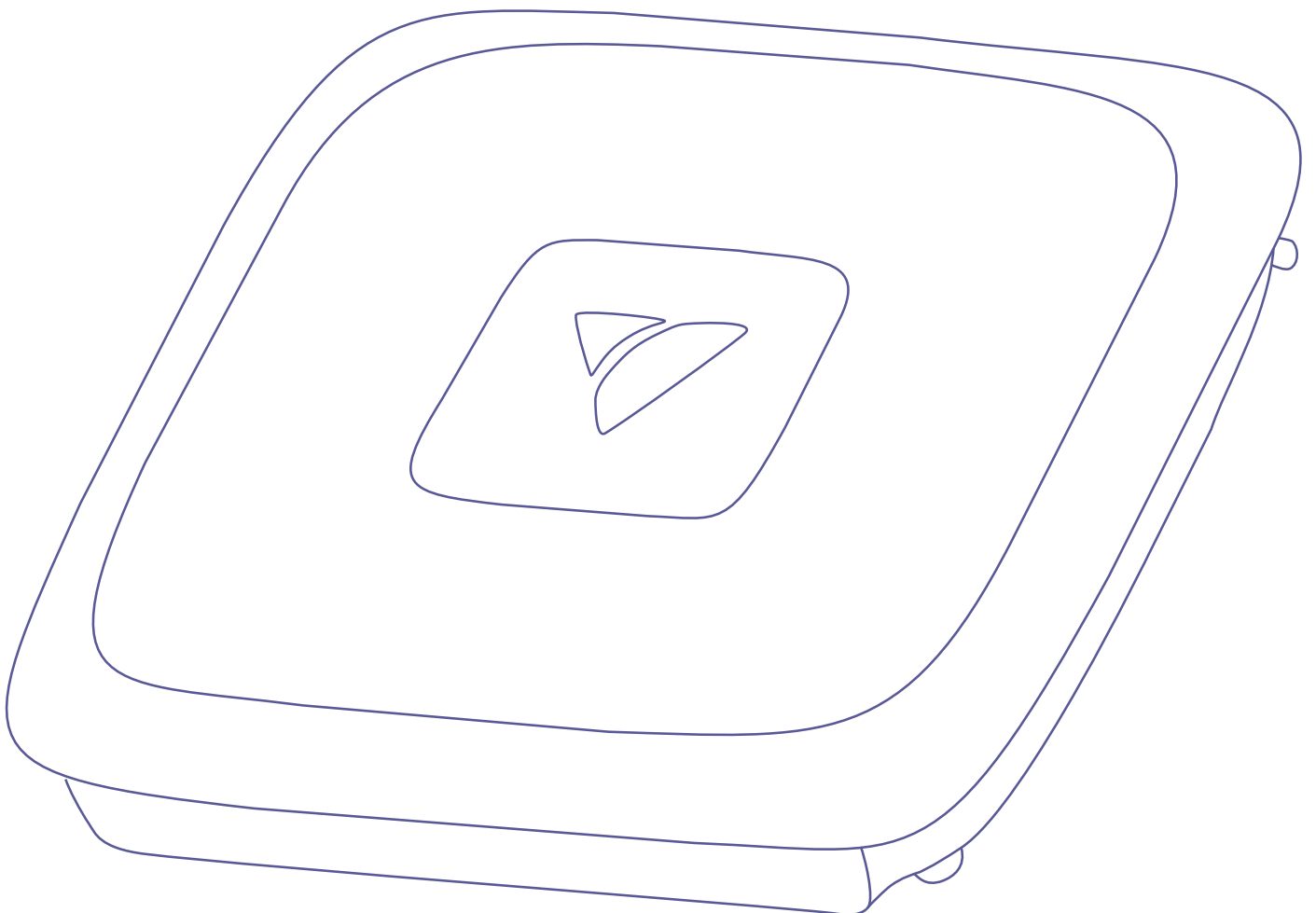

VeevaHub Manager Guide



Contents

Contents	2
List of Tables	3
List of Figures	4
Preface	6
Approval	7
Document History	7
1. Introduction	8
1.1. About Veeahub Manager	8
1.2. What You Need	8
1.3. Using this Guide.....	8
1.4. Please Note	8
2. Getting Started.....	10
2.1. Starting Veeahub Manager	10
2.2. Adding the First Veeahub to your Veeahub Account.....	10
2.3. Manage Screen	13
2.4. Adding More Veeahubs	15
2.4.1. Adding Veeahubs to an Existing Mesh	15
2.4.2. Adding a Veeahub as a New Mesh	15
2.5. Wired Mesh.....	15
2.6. Adding a Veeahub to an Account over 4G Cellular Connection.....	16
2.7. Guides Screen	16
2.8. My Profile Screen	17
2.9. Groups.....	18
2.9.1. Manage Groups Screen	18
3. Using Veeahub Manager	23
3.1. Dashboard	23
3.2. Icons and Links	25
3.3. Common Controls	27
4. Configuration Screens	28
4.1. Wi-Fi Access Point Configuration (2.4GHz and 5GHz).....	28
4.1.1. Wi-Fi Tab (2.4GHz, and 5GHz).....	29
4.1.2. Radio Tab (2.4GHz, and 5GHz).....	31
4.1.3. Wi-Fi Security (2.4GHz, and 5GHz).....	35
4.2. LAN.....	40
4.3. DHCP Settings	43
4.4. Reserved IP Addresses	45
4.5. Router Access Mode and Control	48
4.6. vMesh Configuration	50
4.6.1. vMesh Configuration Screen	50
4.6.2. vMesh Configuration – Wi-Fi Network Scan (MEM Only).....	53

4.7.	IP Address.....	56
4.8.	WAN Gateway	58
4.8.1.	WAN Configuration.....	58
4.8.2.	WAN Interfaces.....	61
4.8.3.	WAN Reserved IPs Tab.....	62
4.9.	Physical Port Configuration.....	64
4.10.	Cellular Usage Analytics.....	70
4.11.	Firewall Configuration	71
4.11.1.	Creating a New Rule.....	71
4.11.2.	Creating a New Accept/Drop Rule.....	72
4.11.3.	Creating a New Firewall Forward Rule.....	73
4.11.4.	Deleting a Firewall Rule	73
4.12.	Services	74
4.13.	Bluetooth Beacon Configuration	74
4.14.	About Veeahub	76
4.15.	Shutdown, Restart or Recover	78
5.	Removing a Veeahub from your Account	80
6.	LAN Configuration	81
6.1.	Default Configuration	81
6.2.	IP Conflict Resolution.....	82
7.	Troubleshooting.....	83
7.1.	Failed Adding the Veeahub.....	83
7.2.	Difficulty connecting to your Veeahub using Veeahub Manager	84
7.3.	DHCP Conflict	84
7.4.	Configuration of VHE09 as MEN in Mixed 09/10 Configurations.....	84
8.	Technical Support.....	86

List of Tables

Table 1 – icon Color Description	24
Table 2 – Dashboard Links Descriptions	25
Table 3 – Common Controls.....	27
Table 4 – Wi-Fi Configuration Description (2.4GHz, and 5GHz).....	29
Table 5 – Wi-Fi Radio Configuration Description (2.4GHz, and 5GHz).....	33
Table 6 – PSK Configuration Options	37
Table 7 – Enterprise Security Configuration Options.....	39
Table 8 – LAN Configuration Description	42
Table 9 – DHCP Configuration Description	43
Table 10 – Reserved IPs Configuration Description	46
Table 11 – Router Configuration Description	49
Table 12 – vMesh Configuration Description.....	51
Table 13 – vMesh Configuration: Scan Tab.....	54
Table 14 – IP Configuration Description	56

Table 15 – WAN Configuration Description	59
Table 16 – WAN Interfaces Configuration Description	61
Table 17 – WAN Reserved IPs Configuration Description	63
Table 18 – Physical Ports Configuration Description	68
Table 19 – Accept and Drop Rules Configuration	72
Table 20 – Forward Rules Configuration	73
Table 21 – Beacon Configuration Description	75
Table 22 – Veeahub Configuration Description	77

List of Figures

Figure 1 – Veeahub Manager App Icon	10
Figure 2 – Veeahub Manager License Screen	10
Figure 3 – Selecting Your Organization	11
Figure 4 – Adding Organization	11
Figure 5 – Login	12
Figure 6 – Manage (Meshes) Screen	13
Figure 7 – Selecting a Veeahub	14
Figure 8 – Connecting to Veeahub	15
Figure 9 – Guides Screen	16
Figure 10 – My Profile Screen	17
Figure 11 – Manage Groups Screen (Example)	19
Figure 12 – Selecting a Mesh (Example)	20
Figure 13 – Connecting to Veeahub	21
Figure 14 – Connecting to Veeahub	22
Figure 15 – Dashboard (Example Layout)	23
Figure 16 – Wi-Fi Configuration	29
Figure 17 – Wi-Fi Access Point – Radio	32
Figure 18 – PSK Configuration	36
Figure 19 – Enterprise Security Configuration	38
Figure 20 – LAN configuration	41
Figure 21 - DHCP configuration	43
Figure 22 – Reserved IP Addresses	45
Figure 23 – Add New Reserved IP Address	46
Figure 24 – Reserved IP Address Configured	47
Figure 25 – Router Configuration	48
Figure 26 – vMesh Configuration	51
Figure 27 – Network Configuration: Scan Description	54

Figure 28 – IP Address.....	56
Figure 29 – WAN Configuration	59
Figure 30 – WAN Interfaces	61
Figure 31 – WAN Reserved IPs.....	62
Figure 32 – Physical Ports Configuration	67
Figure 33 – Cellular Stats.....	70
Figure 34 – Firewall configuration	71
Figure 35 – New Accept or Drop Rule	72
Figure 36 – New Forward Rule.....	73
Figure 37 – Services	74
Figure 38 – Beacon Configuration.....	75
Figure 39 – Veeahub Configuration.....	76
Figure 40 – Power / Reboot	78
Figure 41 – Recovery and Reinstall	79
Figure 42 – Example Error Screen	83
Figure 43 – vMesh Screen (Example)	85
Figure 44 – vMesh Auto Channel Whitelist (Example Popup Box Screen).....	86

Preface

Information in this document is provided solely in connection with Veeva Inc. and its affiliates (collectively 'Veeva') products. Veeva reserves the right to make changes, corrections, modifications or improvements, to this document, and the products and services described herein at any time, without notice.

Use of Veeva products and services is subject to the terms of use and/or separate agreements and warranties applicable to those products and services. Please [visit www.veeva.com/legal](http://www.veeva.com/legal) for these terms.

Evaluators are solely responsible for the choice, selection and use of the Veeva products and services described herein, and Veeva assumes no liability whatsoever relating to the choice, selection or use of the Veeva products and services described herein.

Trademark Credits

Veeva and all Veeva-related trademarks are owned by Veeva Inc.

All other trademarks and tradenames are the property of their respective owners.

Copyright Information and Restrictions

Copyright © 2019-2021 Veeva Inc. All rights reserved.

Document Feedback

Veeva welcomes your suggestions for improving our documentation. If you have comments, send your feedback to: support@veeva.com

Approval

Name	Date	Signature

Document History

Issue	Issue Date	Approved	Author	Description
3.0	2020-09-15		RB	First merged version for Android and Apple
3.1	2020-11-24		RB	Version 2.7.0: User interface changes
3.2	2021-01-20		RB	Version 2.8.0: Multitenancy, Wi-Fi security and Port configuration.
3.3	2021-03-08		RB	Version 2.9.0: Home, Settings, Port and SSID screens changed
3.4	2021-03-31		RB	Version 2.10.0: Client isolation; changes to Dashboard, About Veeahub, Wi-Fi, LAN, DHCP, Reserved IPs, vMesh, Firewall
3.5	2021-04-27		RB	Version 2.11.0: Enhancements to many screens, automatic configuration for wired mesh
3.6	2021-06-03		RB	Version 2.12.0: Changes to some screens. 802.11r added
3.7	2021-08-12		RJ	Version 2.13.0: Addition of wired mesh - wireless islands functionality, groups, VHE09 (MEN) to VHE10 (MN) meshing channels configuration and changes to adding more Veeahubs.

1. Introduction

1.1. About Veeahub Manager

Veeahub Manager is a configuration and diagnostic tool for the Veeahub and networks of Veeahubs. It is used to add new Veeahubs to a network, and to configure the network for specific purposes.

Veeahub Manager is available as an app on both Apple and Android mobile devices. This guide covers both apps.

1.2. What You Need

- Veeahub or Veeahubs running release 2.18.0 platform software or later.
- Phone or tablet running Android 5 or later, or iPhone or iPad running software version 11 or later.
- Veeahub Manager version 2.12.0 or later, available from Google Play for Android devices and from the Apple Store for iPhone and iPad.

1.3. Using this Guide

This guide includes information and instructions for both Android and Apple devices. In general, the screens are very similar, and throughout this document the Android screens are used to illustrate what you can expect to see.

In a few cases there are differences in display or behavior in the two types of device, and in these cases the differences will be highlighted:

Android	Highlight in yellow
Apple	Highlight in blue

1.4. Please Note

The Veeahub range comprises a number of models that are subject to continuing improvement. Not all information in this Guide is applicable to all models, and there are differences of functionality between models.

What you see on the screen may vary depending on:

- The version of Veeahub Manager (Android or Apple)
- The model of Veeahub, how it is configured for the network and what subscribed services it is running
- The type of your mobile device (phone or tablet) and its screen size
- The current release of the Veeahub software
- The current release of the Veeahub Manager app.

Screen images in this document can only be an approximate guide. In specific cases the layout may vary, and particular options may not be available.

Note especially that if you have services installed on your mesh, such as vTPN, those may configure some of the options and they will not be configurable from Veeahub Manager.

2. Getting Started

For a Quick Start Guide to your Veeahub, and other information that is useful if you are new to Veeahub, see veea.com/support.

2.1. Starting Veeahub Manager

To start Veeahub Manager, tap the Veeahub Manager app icon (Figure 1).

Figure 1 – Veeahub Manager App Icon



2.2. Adding the First Veeahub to your Veeahub Account

When you first open the Veeahub Manager app, the License screen shown in Figure 2 is displayed.

Figure 2 – Veeahub Manager License Screen

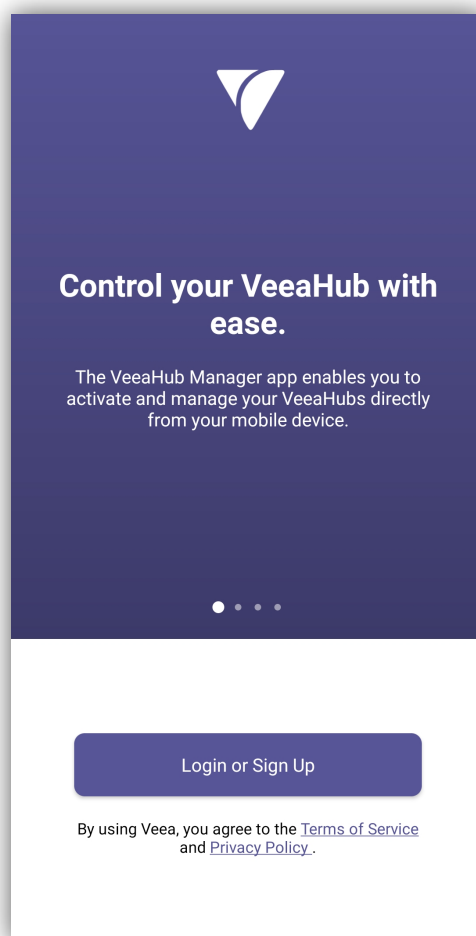

On passing this screen you accept the Veeva Terms of Service and Privacy Policy. If you are not currently logged into your Veeva account, you will be required to log in. If so, the next step is to choose the organization you belong to (Figure 3).

If you are using a VeevaHub in a business or other organization, you will be given the necessary information by your administrator, so select **Add a new Organization**. In other cases, choose the **Veeva** option.

Figure 3 – Selecting Your Organization

← Select organization

Select the organization to log into.
If you do not know your organization, please contact your system administrator.

If you are not part of an organization, use Veeva as the default.

 veeva (default) >

Add a new Organization.. >

If you are in an organization and have been given a login, add the organization name in the screen in Figure 4.

Figure 4 – Adding Organization

← Add Organization

Please enter the name of your organization as it was provided to you to add to your Organization list.

Enter Organization name (required)

Add Organization

If you do not know your Organization, please contact your system administrator.

Log in as shown in Figure 5. If you do not have a Veea account, you can sign up for one at this point.

Figure 5 – Login

The screenshot shows a mobile browser interface for the Veea login page. The address bar at the top shows 'Veea auth.veea.co'. The main content area is titled 'VEEA' and contains a login form with the following elements:

- An 'Email' input field.
- A 'Password' input field.
- A red link labeled 'Forgot Password?'.
- A large teal button labeled 'Login'.
- A link at the bottom that says 'New user? Sign Up'.

If you have a new Veeahub, you should add it to your account at this stage. Follow the instructions on screen. For further information, see veea.com/support

When you add a Veeahub, you can create a new mesh network or you can add the unit to an existing mesh. A mesh is a self-organizing network of Veeahubs.

Note: if you are setting up a network consisting of different models of Veeahubs, the first Veeahub in the network should be a VHE or VHH model.

If your gateway Veeahub is a VHC05, the mesh must be built only with VHC05 Veeahubs.

This step also adds the unit to Veea Control Center, where you can monitor your Veeahubs and mesh networks.

After you have logged in and added the Veeahub to your account, you are taken to the Manage screen (section 2.3), where you can add further Veeahubs, and access your meshes to monitor and configure them.

2.3. Manage Screen

The Veeahub Manager app is used to configure network groups (Refer to Section 2.9), Veeahubs and Veeahub networks to meet your specific requirements. This starts from the Manage (Meshes) screen, Figure 6.

1. Log in to Veeahub Manager. Ensure you are on the Manage screen:



2. Select the network from My Meshes (Figure 6).

Figure 6 – Manage (Meshes) Screen

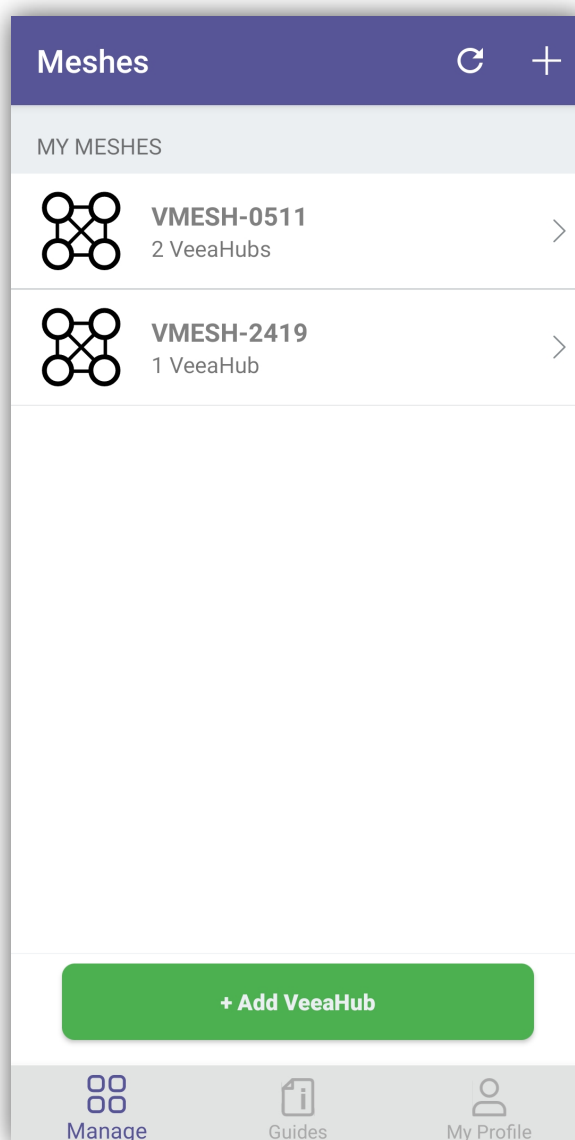

3. All the Veeahubs in the network are listed on the next screen. (If you have a stand-alone Veeahub, just the one is listed here.) Tap the Veeahub you wish to monitor or configure (Figure 7).

Figure 7 – Selecting a Veeahub

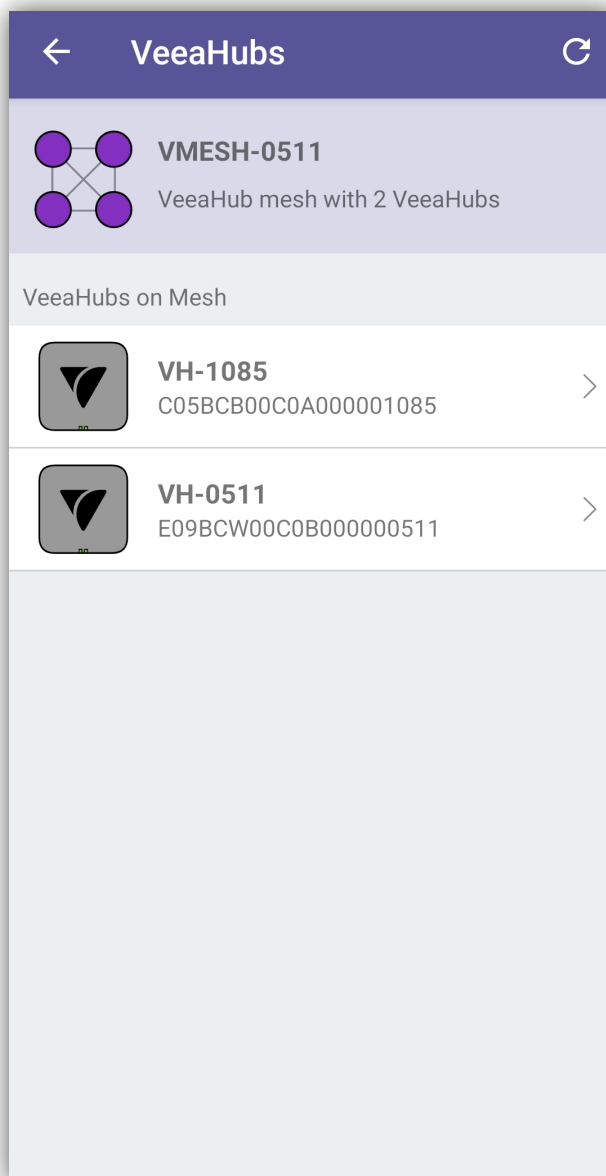

4. After you select the Veeahub, Veeahub Manager connects to it (Figure 8).

Figure 8 – Connecting to Veeahub

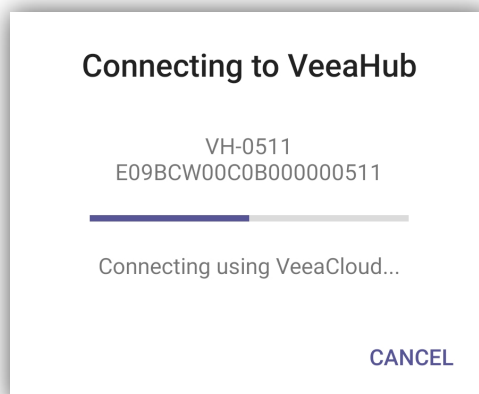

After the selected Veeahub is connected, the Dashboard screen appears as in the example shown in Figure 15. Refer to Section 3 for details of the functions accessible through the Dashboard.

2.4. Adding More Veeahubs

2.4.1. Adding Veeahubs to an Existing Mesh

To add additional Veeahubs to an existing mesh, tap the **+Add Veeahub** button on the Manage screen (Figure 6). Follow the instructions on the screen, including scanning the QR code on the unit. When the 'Select Mesh' screen appears, choose the required vMesh from the available list.

2.4.2. Adding a Veeahub as a New Mesh

To add a Veeahub to form a new mesh, tap the **+Add Veeahub** button on the Manage screen (Figure 6). Follow the instructions on the screen, including scanning the QR code on the unit. When the 'Select Mesh' screen appears, select the **+ Create a new mesh** button. Accept the default mesh name or tap on the name to change it. Configure the Access Point (AP) Wi-Fi details or skip to complete later. Select Continue to complete the setup process.

2.5. Wired Mesh

Veeahubs can be connected into a mesh using Ethernet cable as easily as they can be connected using the default wireless mesh. The wired mesh is automatically configured to provide full connectivity and redundancy. The mesh can include both wired and wireless connections between Veeahubs, or it can be entirely wired or wireless. Once you have activated the hubs you can connect them together with cables as required and the mesh will do the necessary configuration. For more information about different topologies, see veea.com/support

If the mesh is intended to be entirely wired, the wireless mesh can be turned off (section 4.6.1), but this is not essential.

2.6. Adding a Veeahub to an Account over 4G Cellular Connection

The Veeahub can be bootstrapped over a cellular connection. This might be required, for example, where the hub is installed in a remote location, and is intended to use only 4G service as the WAN. To enable this, the unit must come preconfigured for 4G. Alternatively, you should contact Veeva Support for configuration of the device using software on a USB memory stick or SD card.

When configured, the Veeahub holds a database of available Access Point Names (APNs), which are the data required to connect to a designated cellular network compatible with the Veeahub service. If this is not possible because the database is not up to date, contact Veeva Support.

2.7. Guides Screen

The Guides screen (Figure 9) links to information about your Veeahub, Veeahub Manager, and Control Center.

Figure 9 – Guides Screen

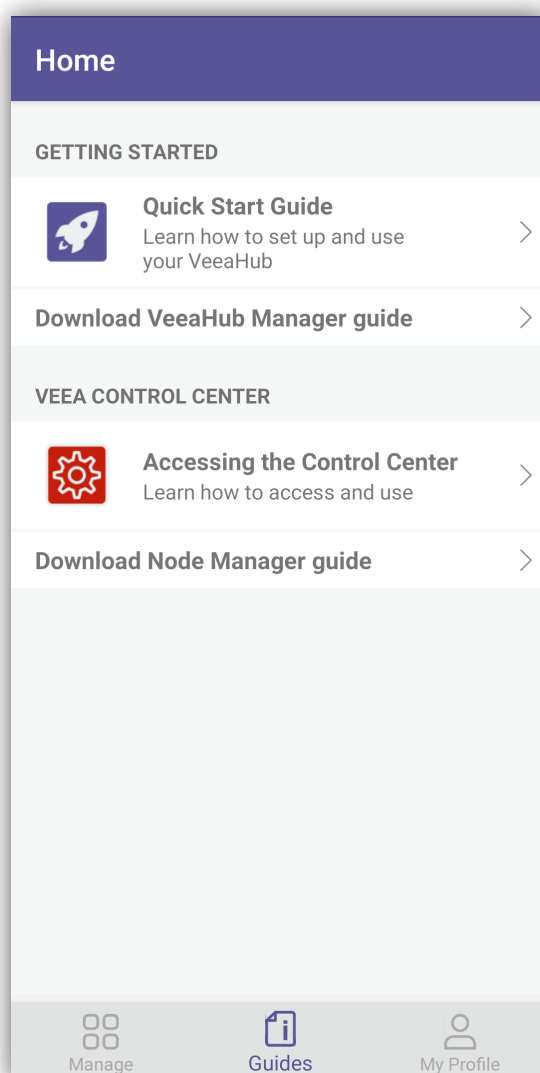

2.8. My Profile Screen

This screen provides links to:

- Change your account password: this changes access to Control Center as well as Veeahub Manager.
- Log out of your account: you will no longer be able to access your Veeahubs with this mobile device until you log in again.
- Access troubleshooting and other help information.
- Access a link to contact Support.

Figure 10 – My Profile Screen

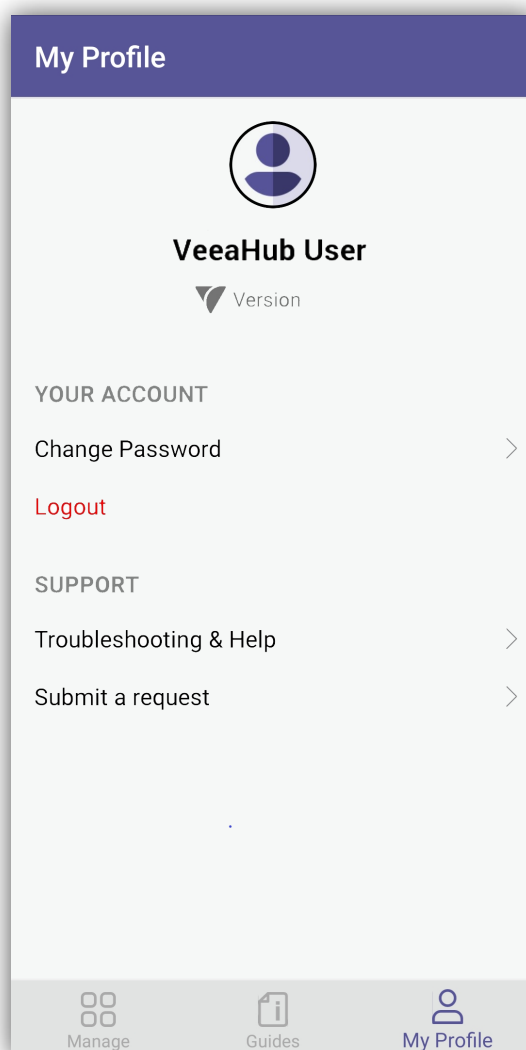

2.9. Groups

Groups provide a centralized administrator feature for networks and Veeahubs from Control Center dashboard. This allows enterprise, company, or individual administrators to have control over, and monitor account portfolio(s), from a single location.

Creation and management of groups is implemented from Control Center. Account holders are invited to join a group and must accept the invite before any group features become available in Control Center and VHM.

For more information on how to set up groups and invite users, See Control Center at <https://www.veea.com/support>.

When your account has been successfully added to a group, the group then becomes visible on the VHM. In this case the screens and navigation to a Veeahub or vMesh change slightly from those described previously in Section 2.3 and these changes are described in Section 2.9.1.

2.9.1. Manage Groups Screen

The procedure to login and manage Veeahubs with accepted groups is described as follows:

1. Log in to Veeahub Manager. Ensure you are on the Manage screen:

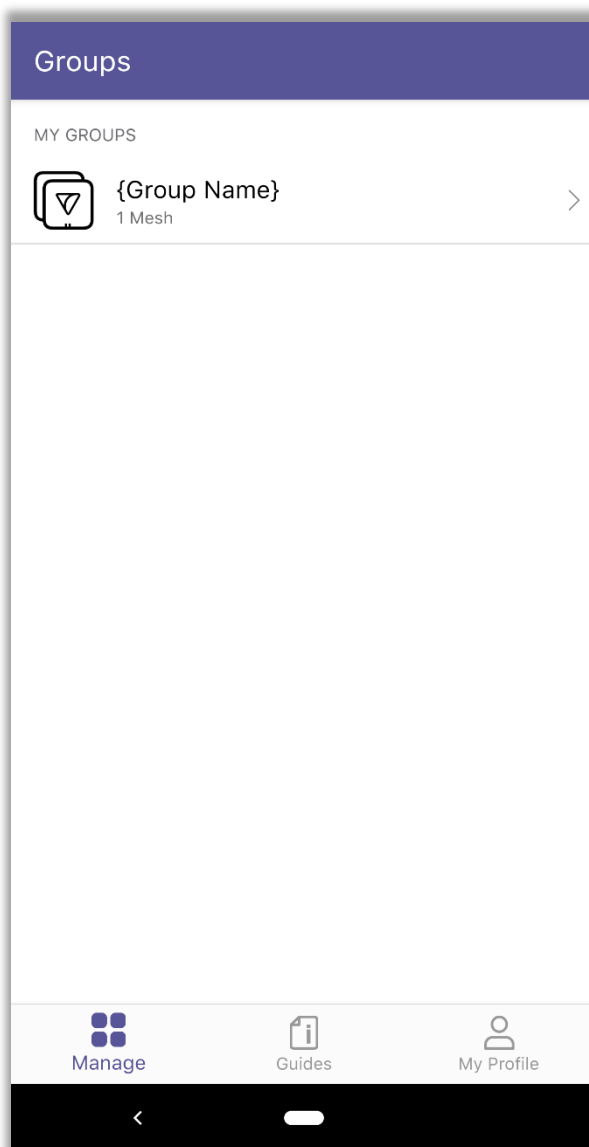

2. As shown in the next screen (Figure 11), all the groups you have been invited to, and have accepted, are listed along with the number of networks in each group. Choose the required group name from the available groups (In this example, only one group is shown).

Figure 11 – Manage Groups Screen (Example)

3. Select the network from My Meshes (Figure 12).

Figure 12 – Selecting a Mesh (Example)

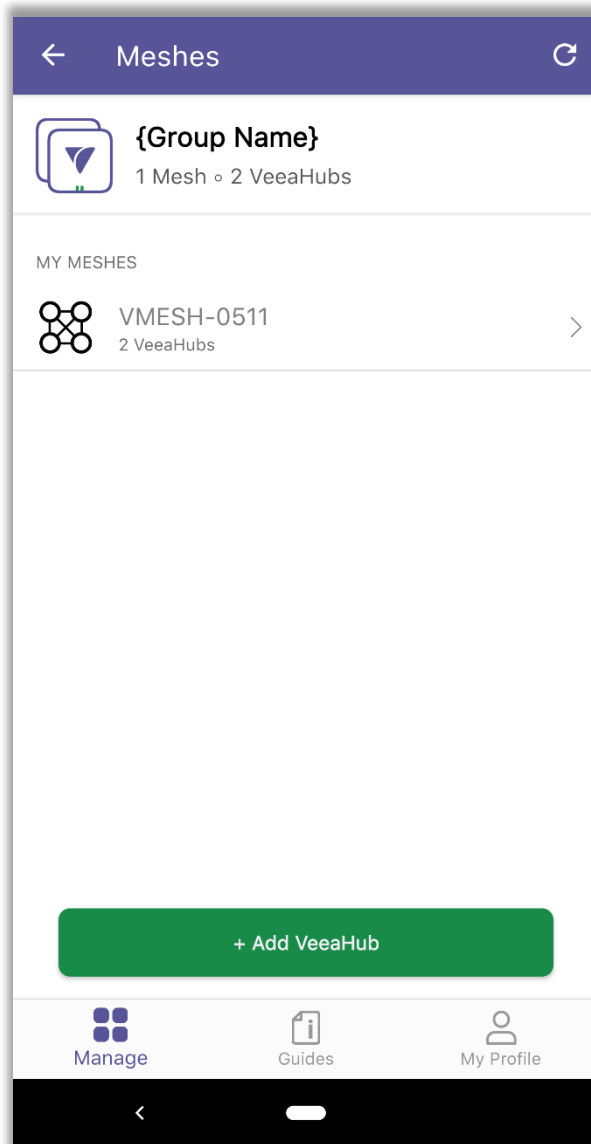

4. All the Veeahubs in the network are listed on the next screen. (If you have a stand-alone Veeahub, just the one is listed here.) Tap the Veeahub you wish to monitor or configure (Figure 13).

Figure 13 – Connecting to Veeahub

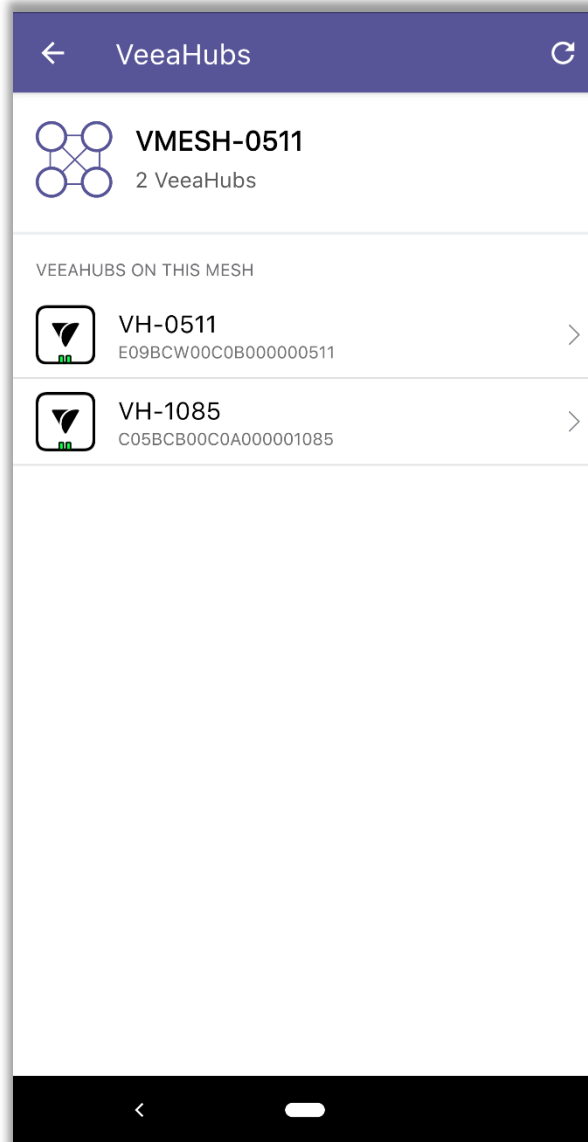

5. After you select the Veeahub, Veeahub Manager connects to it (Figure 14).

Figure 14 – Connecting to Veeahub

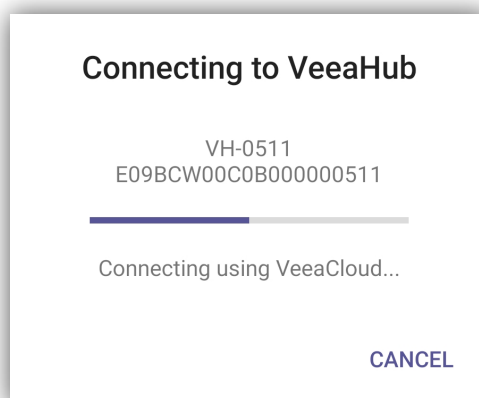

After the selected Veeahub is connected, the Dashboard screen appears as in the example shown in Figure 15. Refer to Section 3 for details of the functions accessible through the Dashboard.

3. Using Veeahub Manager

3.1. Dashboard

The screen displayed when you first connect to a Veeahub is the Dashboard (Veeahub Settings, Figure 15). This shows links to the screens that you can use to configure the Veeahub.

Note that the options you see on the screen depend on the Veeahub model and its current configuration.

Some lines in the Dashboard show additional information, and they may also display warning symbols. The colors of the warning symbols are explained in Table 1.

Figure 15 – Dashboard (Example Layout)

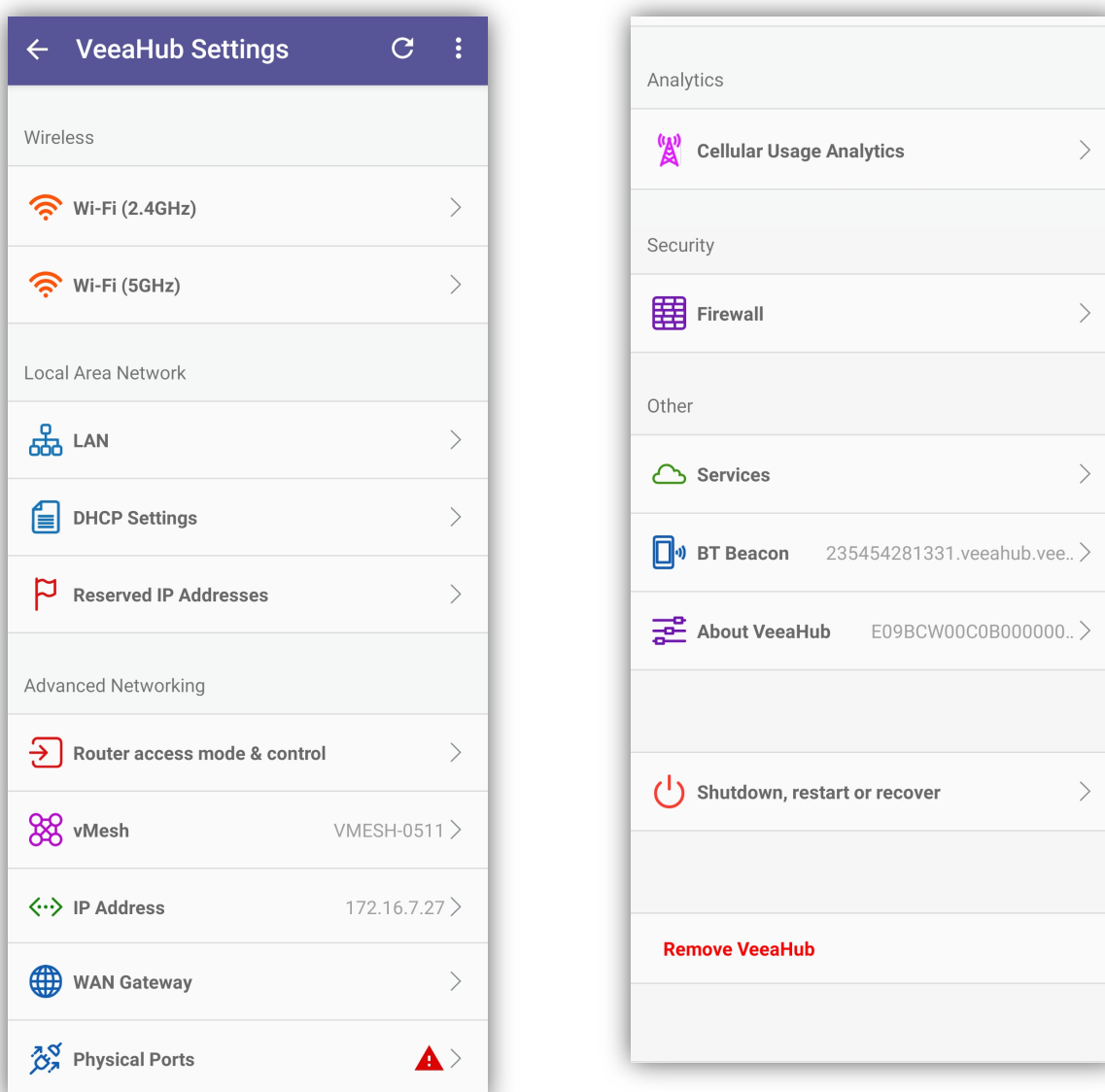

Colored icons indicate the status as described in Table 1.

Table 1 – icon Color Description











icon Color	Description
Amber	The function is in an administrative state and functionality is currently disabled.
Red	The function is not operational.







3.2. Icons and Links

Tap on a Dashboard line to view current status information and to choose configuration options related to that function.

The functions shown in Figure 15 are described in Table 2. Details can be found in the following sections.

Table 2 – Dashboard Links Descriptions

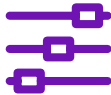
Icon	Description	Function
Network		
	Wi-Fi (2.4GHz)	Opens the Wi-Fi Access Point configuration screen for settings of the 2.4GHz virtual APs. See Section 4.1
	Wi-Fi (5GHz)	Opens the Wi-Fi Access Point configuration screen for settings of the 5GHz virtual APs (where available). See Section 4.1
Local Area Network		
	LAN	Opens the LAN (Local Area Network) configuration screen. See Section 4.2
	DHCP Settings	Opens the DHCP configuration screen for assigning IP address ranges and DNS settings. See section 4.3
	Reserved IP Addresses	Opens the Reserved IPs configuration screen to apply fixed IP addresses to devices. See Section 4.4
Advanced Networking		
	Router access mode & control	Opens the Router configuration screen. See Section 4.5
	vMesh Displays the mesh name	Opens the vMesh configuration screen for mesh settings. See Section 4.6
	IP Address Displays the IP address	Opens the Internet Protocol (IP) address configuration screen. See Section 4.7
	WAN Gateway Displays the current backhaul type	Opens the WAN (Wide Area Network) configuration screens for WAN interface and backhaul settings. See Section 4.8
	Physical Ports	Opens the Physical Ports configuration screen to configure the Ethernet ports. See section 4.9

Icon	Description	Function
Analytics		
	Cellular Usage Analytics	Displays statistics for the cellular backhaul. See Section 4.10
Security		
	Firewall	Opens the Firewall configuration screen, to create or amend Firewall rules. See Section 4.11
Other		
	Services	View interfaces to view information about optional services and subscriptions that you have installed. See Section 4.12
	Bluetooth Beacon Displays the Bluetooth subdomain	Opens the Beacon screen. See Section 4.13
	About Veeahub Displays Veeahub serial number	Opens the About Veeahub screen. See Section 4.14
	Shutdown, Restart or Recover	Opens the Power Control screen, for shutdown, restart and system recovery options. See Section 4.15





The three-dot icon at top right displays the full Veeahub Manager version number, for support purposes.

3.3. Common Controls

Some common controls, as seen in the following screens, and their actions are listed in Table 3.

Table 3 – Common Controls

Android	Function
APPLY	Tap APPLY to close the screen, applying any changes that you have made. These changes are sent to the Veeahub, which then performs the required configuration change.
CANCEL	Tap CANCEL to close the screen without applying changes. The Veeahub Manager returns to the Dashboard screen.
DONE	Tap DONE to leave a screen that gives only information with no configuration options.
 Refresh	Tap this icon to refresh the current screen with updated information.

Apple	Function
Apply	Tap Apply to close the screen, applying any changes that you have made. These changes are sent to the Veeahub, which then performs the required configuration change.
Cancel	Tap Cancel to close the screen without applying changes. The Veeahub returns to the Dashboard screen.
 Back	Tap Back to close the screen without making any changes.
 Refresh	Tap this icon to refresh the current screen with updated information.

4. Configuration Screens

4.1. Wi-Fi Access Point Configuration (2.4GHz and 5GHz)



Tap the Wi-Fi 2.4GHz or Wi-Fi 5GHz option on the Dashboard to configure the wireless Access Points (APs). The Wi-Fi 5GHz option is not enabled on the VCH05 Veeahub unless the wireless mesh is disabled (section 4.6).

Wi-Fi 2.4GHz is used for configuring channels in the 2.4GHz band and Wi-Fi 5GHz is for channels in the 5GHz band. The actual channels available for use depend on your location and national regulations.

The Veeahub supports up to four virtual APs on each band (three on the VHC05). These APs are multiplexed on a single Wi-Fi device across a single Wi-Fi channel, which is configured for all of the four virtual APs.

The configuration is split into two tabs **Wi-Fi** (section 4.1.1) and **Radio** (section 4.1.2).

You may wish to hide one or more SSIDs so that they are not broadcast to Wi-Fi devices. In this case, users will need to know an SSID in order to connect to it.

4.1.1. Wi-Fi Tab (2.4GHz, and 5GHz)

The Wi-Fi tab is shown in Figure 16, with its associated parameters described in Table 4.

These settings allow configuration of Wi-Fi parameters. The tab for 2.4GHz is described here. The tab for 5GHz is similar.

Note that the **Security Type** option does not appear on the VHC05 but is replaced by a simple **Password** option.

Figure 16 – Wi-Fi Configuration

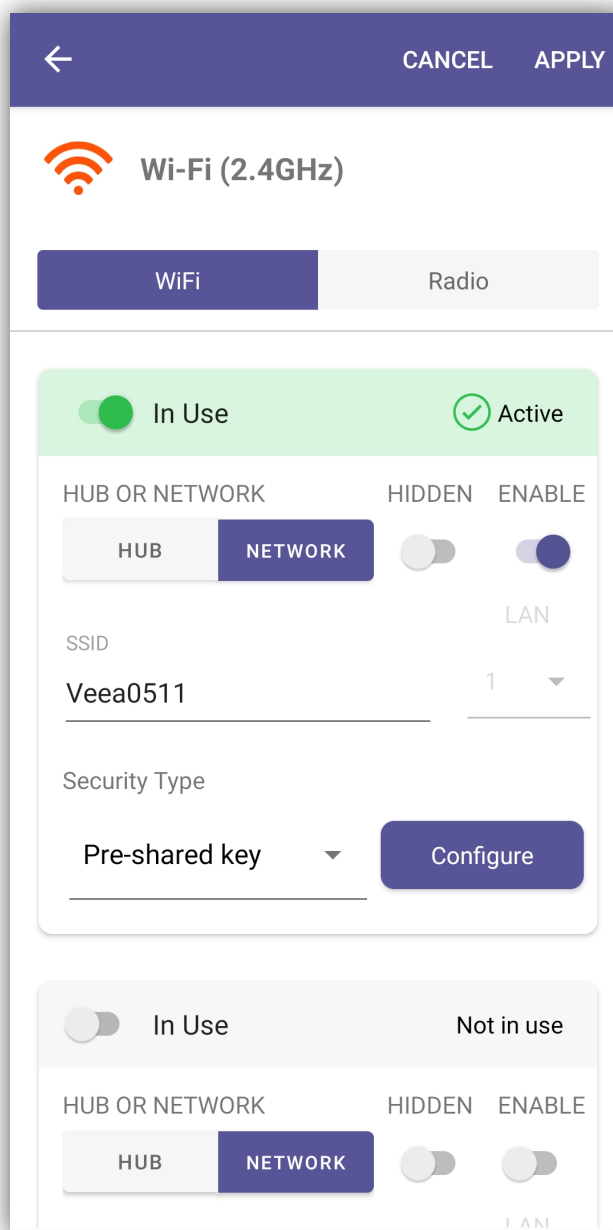

Table 4 – Wi-Fi Configuration Description (2.4GHz, and 5GHz)

Name	Description
In Use	Select the In Use control to use this AP on this hub. If the Enabled switch is on, the AP has the settings that are configured here. If the Enabled switch

	is off, the AP is disabled on this Veeahub, even if it is configured for the whole network (see Hub or Network, below).
Status	At the right of the In Use option, the current status of this AP is displayed with a symbol, for example, Active, Not in use, Disabled, Incomplete, Changes not applied
Hub/Network	On the gateway Veeahub (MEN), set this to Network to apply the settings to this AP on all nodes across the Veeahub network. On any Veeahub, set this to Hub to apply the settings to the AP on this node alone. This overrides any mesh-wide settings for this AP.
Hidden	When set this hides the SSID from client devices.
Enabled	See In Use above.
SSID	This is used to specify the SSID for the virtual AP.
Security Type (not on VHC05)	This displays the type of security in effect on this AP. The default is PSK. Tap on Configure in order to make changes to this setting. For details, see section 4.1.3.
Password (VHC05 only)	Specify a password that the user must enter in order to connect to this AP. Leave blank if a password is not required.
Second, third and fourth virtual AP controls	Scroll down to see these. These are the network controls for the other virtual APs, which replicate the layout as shown above for the first virtual AP.

The icon and background color of an SSID entry give information about the state of the AP. For further details, see the Status message displayed.



Green

The AP is active and properly configured for this setting



Blue

The AP is configured for the network (if Hub is selected) or configured for this Veeahub (if Network is selected)



Orange

The AP is disabled



Red

The AP is non-operational



Yellow

The configuration of this AP is incomplete



No color

The AP is waiting for you to **Apply** a change in configuration

No color

The AP is not in use

4.1.2. Radio Tab (2.4GHz, and 5GHz)

This Radio tab is shown in Figure 17 with its associated parameters described in Table 5.

Use this tab to set radio configuration options for the 2.4GHz APs. The screen for 5GHz range is similar.

The available channels depend on the country where the Veeahub has been registered, because local regulations vary. They also depend on the capabilities of the Veeahub model, for example, the VHE10 has upper and lower 5GHz bands.

When Auto Selection is on, the AP channel is automatically chosen for you, based on various measurements of the quality of the signal. These measurements can be seen using the **Wi-Fi Network Scan** option. You can override this selection by choosing a single channel from those available, and you can also restrict the selection of channels that Auto Select uses.

Auto Select is not dynamic: once the channel has been selected, this applies until the Veeahub is restarted, or until you choose another option.

Auto Select is not available in certain circumstances, for example, on the VHC09 the 5GHz radio is shared by the APs and the wireless mesh, and the frequency channel is selected by the option on the Mesh screen (section 4.6).

For Veeahubs registered in the UK: UK regulations were changed in August 2017 to allow Wi-Fi usage on channels 144, 149, 153, 157, 161 and 165. Older mobile devices supplied in the UK may not be able to connect to those channels. If there are problems connecting to the Veeahub network on the 5GHz band, we recommend excluding those channels from the Auto Channel whitelist.

Figure 17 – Wi-Fi Access Point – Radio

← CANCEL APPLY

 **2.4GHz Configuration**

WiFi Radio

Channel: Auto Selection ▼

Channel In Use: 20

Auto Channel Whitelist: 1, 6, 11 ▼

WiFi Network Scan: >

Bandwidth: 20 ▼

Bandwidth In Use: 20

Mode: mixed (b/g/n/ac) ▼

MAX STATIONS

128

MAX INACTIVITY (seconds)

300

TRANSMIT POWER SCALE (%):

100 ▼

Table 5 – Wi-Fi Radio Configuration Description (2.4GHz, and 5GHz)

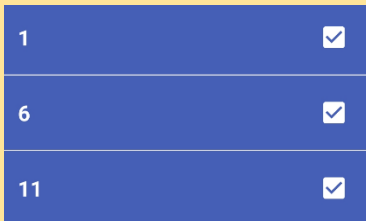
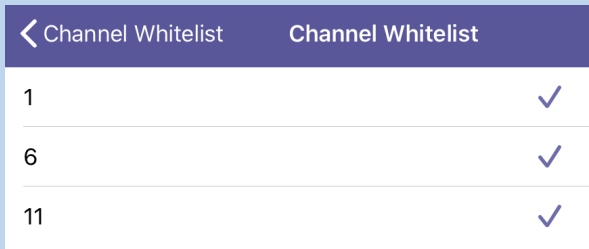
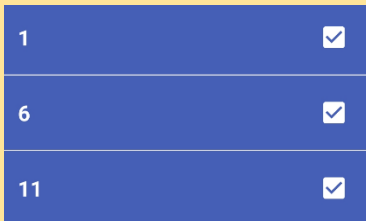
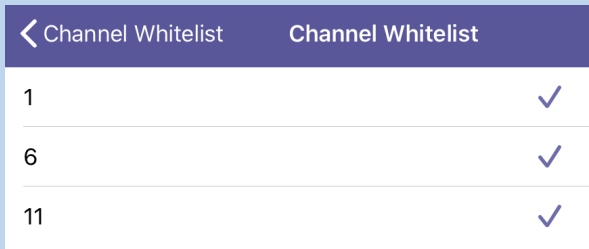
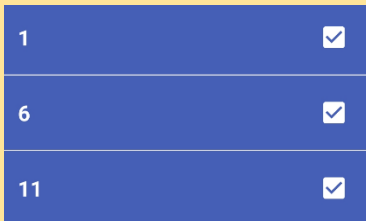
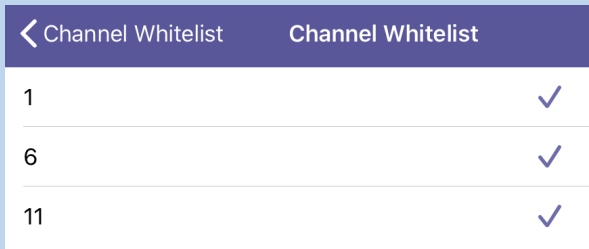
Name	Description				
Channel	This is used by all four APs. By default, Auto Selection is displayed (when available). Wi-Fi uses a number of criteria to choose the best channel at the time the APs start up. If you prefer to override this and select one of the available channels, choose the channel number from the drop-down list.				
Channel in Use	Displays the auto selected channel number.				
Auto Channel Whitelist	<p>This enables you to select the channels from which the auto selection occurs. Tap on the drop-down icon, select or deselect the channels as required, then tap OK.</p> <table border="1" data-bbox="568 667 1382 1178"> <tbody> <tr> <td data-bbox="568 667 695 909">Android</td> <td data-bbox="695 667 1382 909">  </td> </tr> <tr> <td data-bbox="568 909 695 1178">Apple</td> <td data-bbox="695 909 1382 1178">  </td> </tr> </tbody> </table>	Android		Apple	
Android					
Apple					

Name	Description
Wi-Fi Network Scan	<p>Auto Channel Scan is available on the VHC05, but these metrics are not displayed.</p> <p>Tapping on the > icon displays a page showing the measurements for each channel on which the auto selection is based. It also shows the date and time these measurements were made. A typical result is shown here.</p> <div data-bbox="743 495 1198 1402" style="border: 1px solid #ccc; padding: 10px; margin: 10px auto; width: fit-content;"> <p>The screenshot shows a mobile application interface for 'Radio 1'. At the top, there is a back arrow, the title 'Radio 1', and a 'RESCAN' button. Below the title, it says 'Last Scan: 2021-2-23 (17:30:10)'. The interface displays three channel scan results, each in a separate section:</p> <ul style="list-style-type: none"> Channel: 1 (Rank 1): #BSS Detected: 8, Min/Max RSSI for BSS: -82/-45, Noise Floor/dBm: -95, Load: 23. Channel: 6 (Rank 3): #BSS Detected: 7, Min/Max RSSI for BSS: -53/-41, Noise Floor/dBm: -90, Load: 22. Channel: 11 (Rank 2): #BSS Detected: 9, Min/Max RSSI for BSS: -92/-43. </div> <p>The measurements are:</p> <ul style="list-style-type: none"> • #BSS: the number of basic service sets (BSS) detected on this channel • The minimum and maximum Received Signal Strength Indicator for the BSSs on this channel • The noise floor on this channel • Load: A measure of the time the channel is occupied <p>These measurements are combined to select a best channel for the auto select. If a channel is ranked as 0, it is not considered suitable for auto selection. If all the channels show poor results, then moving the Veeahub to another position should be considered.</p> <p>You can rescan the measurements by tapping RESCAN. This may change the channel used.</p>

Name	Description
Bandwidth	This sets the channel selection spread, which is dependent on the channel in use. This is grayed out when the option is not available. Possible options include: <ul style="list-style-type: none"> • 20MHz • 20MHz/40MHz • 20MHz/40MHz/80MHz If you are selecting this when ACS is active, ensure that the bonded channels are included in the Auto Channel Whitelist.
Bandwidth in Use	This displays the channel bandwidth in use.
Mode	Selects the 802.11 standard to use.
Max stations	Specifies the maximum number of clients per AP.
Max inactivity (in seconds)	Specifies the maximum inactivity time after which the client is disconnected from the AP.
Transmit Power Scale (%)	Specifies the AP transmit power.

4.1.3. Wi-Fi Security (2.4GHz, and 5GHz)

The Veeahub offers three security types: **Open**, **Pre-Shared Key (PSK)** and **Enterprise**. The default is PSK. Different APs on one Veeahub can be configured with different security types.

Note: This does not apply to the VHC05 model, which has only PSK, which can be configured with or without a password.

Use Open if you do not require the user to enter a password in order to connect to an AP. There are no further configuration options.

PSK is the default and is used if you want the user to know a password in order to connect to the AP.

Enterprise security requires authentication on a separate server called a Remote Authentication Dial-In User Service (RADIUS) server. This option will typically be used if the Veeahub is installed in a business network where this security type is used.

In the Wi-Fi tab (Figure 16), tap on the Security Type drop-down to select a different option.

The following subsections describe the different options.

Open security

No password is required for anyone to connect to an AP with Open security. There are no further options to set.

PSK security

A password must be set up on the Veeahub. This password must be known by a user in order to connect their mobile device to this AP.

The PSK options are shown in Figure 18 and Table 6.

Figure 18 – PSK Configuration

← Pre-Shared Key (PSK)

SSID

Veea0511

WPA MODE

WPA2 Only ✓

WPA3 Only

WPA2 and WPA3

PASSPHRASE

.....

802.11r

Enabled ✓

802.11r allows compatible Wi-Fi clients to fast transition (FT) between network APs that are configured with the same SSID. Enabling 802.11r may mean some older clients cannot connect to this SSID.

802.11w

Enabled

802.11w allows compatible Wi-Fi clients to use management frame protection as an additional security measure for management frames

Table 6 – PSK Configuration Options

Name	Description
SSID	Not editable in this screen, see section 4.1.1.
WPA Mode	You can select to allow client devices to connect with WPA2 only, WPA3 only, or either.
Passphrase	Enter the required passphrase here, 8-63 characters.
802.11r	When set, this enables client devices to fast transition between network APs that are configured with the same SSID. This is currently available only on the 09/10 models. Enabling 802.11r may mean that some older devices without this capability cannot connect to this SSID.
802.11w	This option is available only when WPA2 Only is selected. The values are Enabled, Disabled or Required . This enhancement to security is set to Enabled by default: devices with or without 802.11w can connect. If set to Required, only devices that support 802.11w will be able to connect.

Enterprise security

This option is for Veeahubs in enterprise networks. Your system administrator will provide necessary information.

Authentication is performed by contacting a specialized server, called a RADIUS Authentication server. RADIUS may also be used to collect data on usage for billing purposes on an Accounting server. These servers must already be configured before this security option can be used.

RADIUS server details must be set up on the gateway Veeahub (MEN) before a selection can be made on other nodes in the mesh.

The Enterprise security options are shown in Figure 19 and Table 7.

Figure 19 – Enterprise Security Configuration

← Enterprise

SSID

Veea0511

WPA MODE

WPA2 Only ✓

WPA3 Only

WPA2 and WPA3

802.11r

Enabled ✓

802.11r allows compatible Wi-Fi clients to fast transition (FT) between network APs that are configured with the same SSID. Enabling 802.11r may mean some older clients cannot connect to this SSID.

802.11w

Enabled

802.11w allows compatible Wi-Fi clients to use management frame protection as an additional security measure for management frames

RADIUS AUTHENTICATION

Primary: Not configured >

Secondary: Not configured >

Tap to view details and select configured servers. (Server configurations can only be edited on the Management Node)



RADIUS ACCOUNTING

Primary: Not configured >

Secondary: Not configured >

Tap to view details and select configured servers. (Server configurations can only be edited on the Management Node)

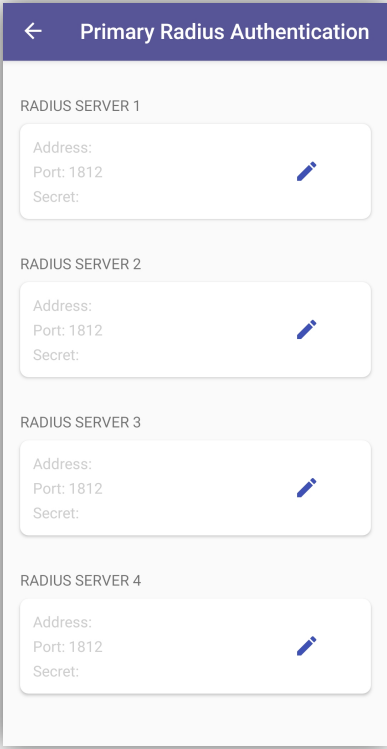
Table 7 – Enterprise Security Configuration Options

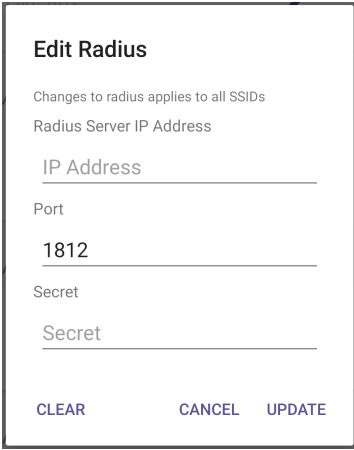
Name	Description
SSID	Not editable in this screen, see section 4.1.1.
WPA Mode	You can select to allow client devices to connect with WPA2 only, WPA3 only or either.
RADIUS Authentication	<p>Tap the  icon to edit the RADIUS server details. Primary and secondary servers can be configured. The secondary server is optional and acts as a backup if the primary server is unavailable.</p> <div data-bbox="783 600 1171 1346" style="border: 1px solid #ccc; padding: 10px; margin: 10px auto; width: fit-content;">  </div> <p>For each server, click on the  icon to enter the required details: the IP Address of the server, the port number (default 1812) and the secret for access to the server.</p> <p>The secret must be known by a user in order to connect their mobile device to this AP.</p> <div data-bbox="823 1581 1177 2029" style="border: 1px solid #ccc; padding: 10px; margin: 10px auto; width: fit-content;">  </div>

RADIUS Accounting	Enable the switch if this option is required. The configuration is similar to RADIUS Authentication. The default port number for RADIUS accounting is 1813.
--------------------------	---

4.2. LAN



This screen appears only on the MEN (gateway node).

Tap the LAN option on the Dashboard to configure LANs on the Veeahub network. The LAN screen is shown in Figure 20 and its associated parameters are described in Table 8.

This screen is used to configure up to four LANs on the Veeahub network. You should use this screen to link your AP settings (section 4.1) with your WAN settings (section 4.8).

Figure 20 – LAN configuration

←
CANCEL
APPLY

LAN

LAN 1
LAN 2
LAN 3
LAN 4

Active

Lan Name

default

IPv4 Subnet

10.0.0.0/24

Client Isolation

ACCESS POINTS

	1	2	3	4
AP1	<input checked="" type="checkbox"/>	<input type="checkbox"/>	<input type="checkbox"/>	<input type="checkbox"/>
AP2	<input checked="" type="checkbox"/>	<input type="checkbox"/>	<input type="checkbox"/>	<input type="checkbox"/>

Select which virtual APs have access to this LAN

ETHERNET PORTS

	1	2	3	4
Port	<input checked="" type="checkbox"/>	<input checked="" type="checkbox"/>	<input checked="" type="checkbox"/>	<input checked="" type="checkbox"/>

Select which ethernet ports can access this LAN

WAN

WAN mode: Routed ▼

WAN INTERFACE

1

Table 8 – LAN Configuration Description

Name	Description
Tabs	Used to select the LAN to be configured.
Active	Set this switch to ON to make the LAN active
LAN Name	Set the name of the LAN.
IPv4 Subnet	Specifies the allowable IP addresses assign to this LAN. For example, 10.1.0.0/24
Client Isolation	If this switch is set to ON, devices on this LAN cannot see each other.
ACCESS POINTS	
AP1: 2.4GHz	Each toggle button enables/disables routing of this Local Area Network (LAN) to the corresponding 2.4GHz virtual AP.
AP2: 5GHz	Each toggle button enables/disables routing of this Local Area Network (LAN) to the corresponding 5GHz virtual AP.
ETHERNET PORTS	
Port	Each toggle button enables/disables routing of this Local Area Network (LAN) to the corresponding Ethernet port.
WAN	
WAN routed/bridged	Select whether this LAN is routed or bridged to the WAN.
WAN Interface	This must be the number of the WAN interface in Figure 30 to which you are connecting this LAN.

4.3. DHCP Settings



Tap the DHCP option on the Dashboard to configure DHCP. This screen is shown in Figure 21 with its associated parameters described in Table 9. It is available only on the gateway node (MEN).

Use this screen to configure a DHCP server for each LAN that has been configured on the LAN configuration tab (section 4.2) where you have enabled DHCP. You can also configure DNS nameservers for each LAN here.

Figure 21 - DHCP configuration

Table 9 – DHCP Configuration Description

Name	Description
Tabs LAN 1...	Used to select the LAN to be configured with DHCP.
Lease Time	Set the Lease Time in minutes.
DNS 1	Set the primary nameserver, for example, 8.8.8.8 for Google.

Name	Description
DNS 2	Set the secondary nameserver, for example, 8.8.4.4 for Google.
Start IP	Set the start IP of the range for this LAN.
End IP	Set the end IP of the range for this LAN.
#IP	The number of IPs in the defined range (calculated automatically from the preceding fields).
Subnet Mask	This is defined in section 4.2. The settings in this screen must match this.
DHCP controls for the second, third and fourth LANs	These replicate the layout as shown for LAN1.

4.4. Reserved IP Addresses



Individual devices on wireless APs or LAN ports can be assigned reserved IP addresses. You can add up to 10 reserved IP addresses on each LAN. Tap the Reserved IPs option on the Dashboard to display the Reserved IP Addresses screen. If there are no reserved IPs currently configured, this screen is as shown in Figure 24.

This screen is available only on the gateway Veeahub. The setting is disabled if it is managed on the WAN, for example, if the LAN is bridged to the WAN, or if it is managed by an installed service such as vTPN.

Figure 22 – Reserved IP Addresses

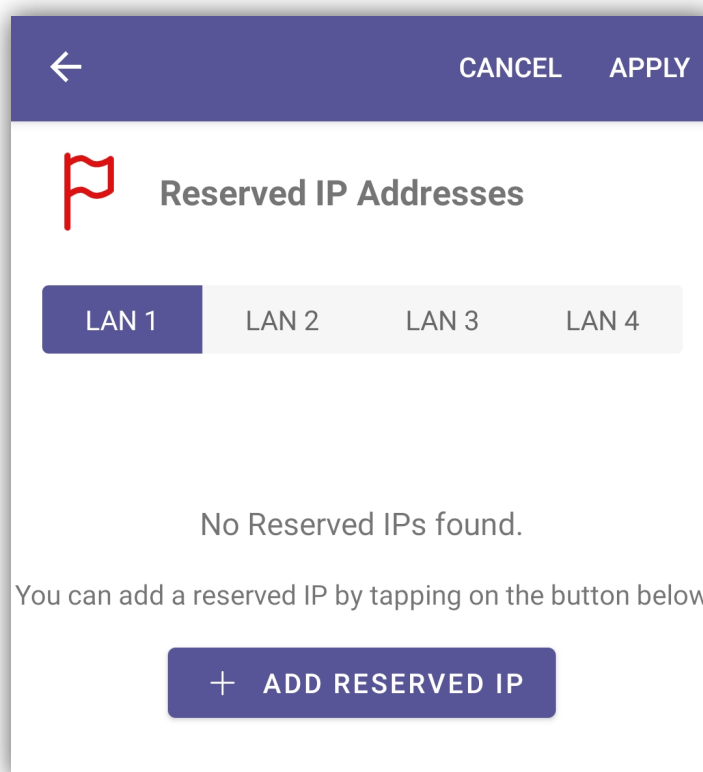

To add a reserved IP tap the **+Add Reserved IP** button. The Add New Reserved IP dialog is displayed as shown in Figure 23 and its associated parameters are described in Table 10.

After you have entered the details, tap **Add** to add the reserved IP address.

When you have added one or more reserved IP addresses, you must restart the unit for the changes to take effect.

Figure 23 – Add New Reserved IP Address

Reserved IP Addresses

Add New Reserved IP

Active

Device Name

Device Mac Address

Assign IP

Comment

* Enter either the device name OR the device MAC address AND the IP address

CANCEL ADD

Table 10 – Reserved IPs Configuration Description

Name	Description
Active	When switched on, the Reserved IP is in effect.
Device Name	Specify the name of the device you wish to assign the IP address to. This is an alternative to specifying the MAC address. How to find the device name depends on the type of the device.
Device MAC address	Specify the MAC address of the device you wish to assign the IP address to. This is an alternative to specifying the Device Name.
Assign IP	Enter the IP address to assign to this device on this LAN.
Comment	A free text field to record information about this reserved IP address.

Once you have one or more reserved IP addresses configured, the screen appears as in Figure 24.

Figure 24 – Reserved IP Address Configured

← CANCEL APPLY

Reserved IP Addresses

LAN 1 LAN 2 LAN 3 LAN 4

RESERVED IP 1

Active Clear Fields

Device Name
NewDevice

Device MAC address

Assign IP
10.100.1.200

Comment

Remove

* Enter either the device name OR the device MAC address AND the IP address

- To clear the details from a reserved IP address, tap **Clear Fields**.
- To delete the reserved IP address, tap **Remove** and restart the unit to apply the changes.

4.5. Router Access Mode and Control



Tap the Router Access Mode and Control option on the Dashboard to show the Router configuration screen (Figure 25). The details are in Table 11. This screen is available only on the gateway Veeahub.

This screen shows configurations relating to:

- Connecting to a router on the WAN
- Access control for devices on wireless APs.

Figure 25 – Router Configuration

The screenshot displays the 'Router access mode & control' configuration screen. At the top, there is a navigation bar with a back arrow, 'CANCEL', and 'APPLY' buttons. Below the title, the screen is divided into two main sections: 'WAN settings' and 'WLAN settings'.
Under 'WAN settings', the 'Access mode' is set to 'Dynamic'. The 'PPPoE username' is 'user', and the 'PPPoE passphrase' is masked with dots and has a visibility toggle icon.
Under 'WLAN settings', the 'Access Control' section features a toggle between 'ACCEPT' (selected) and 'DENY'. Below this, there is a MAC address input field with the placeholder '00 : 00 : 00 : 00 : 00 : 00' and a 'Remove' button. A '+ Add New' button is located at the bottom of the WLAN settings section.

Table 11 – Router Configuration Description

Name	Description
WAN SETTINGS	
Access Mode	<p>Set from the menu.</p> <p>If the Veeahub WAN port is connected to an external router, set this option to Dynamic (default).</p> <p>If the Veeahub WAN port is connected to an external router configured for Point to Point Protocol over Ethernet (PPPoE), select the PPPoE option.</p> <div style="border: 1px solid #ccc; padding: 5px; margin-top: 10px;"> <p>Dynamic</p> <p>PPPoE</p> </div>
PPPoE username	Set the username for PPPoE.
PPPoE passphrase	Set the passphrase for PPPoE.
 Eye icon	Tap to reveal or hide the passphrase.
WLAN SETTINGS	
Access Control	<p>Access Control provides options for acceptance (Accept) or denial (Deny) of access to the wireless APs for a device with a given MAC address. You can set up lists of allowed and denied devices.</p> <p>To add a new device to a list set the switch to Accept or Deny, then tap the Add New.</p> <p>Enter the required MAC address.</p> <p>Note. All MAC addresses are allowed by default.</p>
Remove	Tap to delete the access control entry on that line.

4.6. vMesh Configuration

4.6.1. vMesh Configuration Screen



Tap the vMesh configuration option on the Dashboard to open the vMesh Configuration screen shown in Figure 26. The details are in Table 12.

vMesh is Veeva's proprietary technology that enables the Veeahubs in a network to work together. For further information, see the Veeahub Support Center. This and other mesh parameters can be configured on this screen.

By default, the mesh is established over 5GHz Wi-Fi. It is possible to reconfigure Veeahubs to connect over Ethernet. A Veeahub mesh can consist of wireless links, wired links or a mixture of the two.

The mesh name and default parameters are set up when the Veeahub is added to the account. You may wish to change the channel assignments and transmit power for improved operation in your particular circumstances (including location of units and usage of the mesh).

When Auto Selection is on, the Wi-Fi channel used for the mesh is automatically chosen for you, based on various measurements of the quality of the signal. You can override this selection by choosing a single channel from those available, and you can also restrict the selection of channels that Auto Select uses.

Auto Selection is available only on the VHE09 and VHE10 models.

Auto Select is not dynamic: once the channel has been selected, this applies until the Veeahub is restarted, or a channel rescan is done.

Figure 26 – vMesh Configuration

←
APPLY

vMesh

i More about this page
>

Mesh Name

E09BCWE0C0B000000605-vmesh

SSID

VMESH-0605

Password

●●●●●●●●●●●●●●●●

WLAN Enabled (Wired Hubs)

WLAN Operation (Local Hub) Start network ▼

Channel Auto Selection ▼

Channel In Use 44

Exclude DFS

Auto Channel Whitelist 36, 40, 44, 48 ▼

Wi-Fi Network Scan >

Bandwidth 20/40 ▼



Bandwidth In Use 40

Transmit Power (%) 100 ▼

Table 12 – vMesh Configuration Description

Name	Description
Mesh Name	The name of the network, usually assigned when the first Veeahub is added to the Veea account and used to create the mesh. The name can be changed here.

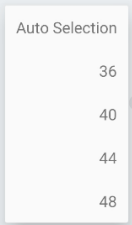
Name	Description
SSID	The SSID used for the network WLAN. 1 to 32 characters.
Password	The password for the network WLAN. 8 to 63 characters (letters, digits or symbols).
 Eye icon	Tap to reveal the password.
WLAN Enabled (Wired Hubs) ⁽ⁱ⁾	<p>For a gateway Veeahub (MEN):</p> <p>In the on position, the wireless network operation is enabled for any connected wired hubs. This allows the network to extend wirelessly from these units.</p> <p>In the off position, the wireless networking is disabled on any directly wired, remote hubs that have WLAN Operation set to 'Automatic'. The network cannot be extended with wireless links from these units.</p> <p>For a non-gateway Veeahub (MN):</p> <p>This is a read-only setting that is configured at the gateway hub. In the on position, the wireless network operation is enabled according to the 'WLAN Operation (Local Hub)' setting. This allows the network to extend wirelessly from these units.</p> <p>In the off position, the wireless operation is disabled at this hub provided it has a direct wired link to the gateway hub and also that the 'WLAN Operation' setting is 'Automatic'. Otherwise, the normal 'WLAN Operation' setting behavior applies.</p>
WLAN Operation (Local Hub) ⁽ⁱ⁾	<p>For a gateway Veeahub (MEN):</p> <ul style="list-style-type: none"> • With 'Start Network' selected, the hub supports wireless networking and will start a network identified by the SSID setting. Other hubs can connect to this unit wirelessly using the SSID and matching PSK. • With 'Disabled' selected, the wireless networking is disabled, and the network cannot be extended with wireless links from this hub. <p>For a non-gateway Veeahub (MN):</p> <ul style="list-style-type: none"> • With 'Disabled' selected, the wireless networking is disabled, and the network cannot be extended with wireless links from this hub. • With 'Automatic' selected, the behavior depends on whether this unit has a direct wired connection to the gateway hub, and also the setting of 'WLAN Enabled (Wired Hubs)'. If there is no direct wired connection then this unit joins an existing wireless network, similar to the 'Join Network' setting. If there is a direct wired connection and 'WLAN Enabled (Wired Hubs)' is off, then wireless networking is disabled on this unit, similar to the 'Disabled' setting. If there is a direct wired connection and 'WLAN Enabled (Wired Hubs)' is on, then the unit first attempts to join an existing network and, if this is unsuccessful, it starts a new wireless network. • With 'Join Network' selected, the hub will join an existing wireless network identified by the SSID and provided the PSK matches. The hub must be in range of the existing wireless network. • With 'Start Network' selected, the hub will start a wireless network using the SSID setting. Other wireless hubs can then connect to this. Note that if two hubs are in proximity and both start a network with the same SSID, then the networks are independent.
Channel	This enables selection of the Wi-Fi channel for the wireless mesh. The set of available channels is restricted, based on the configured Veeahub location.

Name	Description
	<p>By default, Auto Selection is displayed. A number of criteria are used to choose the best channel at the time the mesh starts up. If you prefer to override this and select one of the available channels, choose the channel number from the list.</p> 
Channel in Use	The channel chosen by Auto Selection.
Exclude DFS	This switch, when selected, prevents channels that are designated for Dynamic Frequency Selection being used for Auto Selection.
Auto Channel Whitelist	This dropdown enables you to specify which channels will be used for Auto Channel selection.
Wi-Fi Network Scan	When Auto Select is in operation, this displays the Scan screen (section 4.6.2)
Bandwidth	<p>Select the bandwidth for the network LAN. Note: 80MHz is not supported on the VHC05.</p> 
Bandwidth in Use	This shows the currently selected bandwidth.
Enable Beacon	Not available on a gateway node (MEN). This is used on a non-gateway node (MN) to create a new Wi-Fi mesh using the SSID above. In normal use this should be OFF at all nodes.
Transmit Power (%)	Select the mesh transmit power (as a % of maximum).
Note.	<p>⁽ⁱ⁾These settings support deployment of a mixed wireless and wired network, for example adding a wireless extension to a wired network. The default settings cover most configurations when first deploying a network, and once deployed, the default settings can be updated to match the network topology more precisely. For more information visit the Veea Support site at: https://www.veea.com/support</p>

4.6.2. vMesh Configuration – Wi-Fi Network Scan (MEM Only)

This tab (Figure 27), when it appears, shows the measurements for each channel on which the Auto Channel selection is based. It also shows the date and time these measurements were made. A typical result is shown here.

Figure 27 – Network Configuration: Scan Description

Channel: 36 (Rank 2)	
#BSS Detected	Min/Max RSSI for BSS
2	-50/-31
Noise Floor/dBm	Load
-110	1

Channel: 44 (Rank 1)	
#BSS Detected	Min/Max RSSI for BSS
2	-49/-49
Noise Floor/dBm	Load
-110	4

Channel: 40 (Rank 3)	
#BSS Detected	Min/Max RSSI for BSS
0	-95/-95

The measurements are listed in Table 13.

Table 13 – vMesh Configuration: Scan Tab

Channel	The channel number.
Rank	A number calculated from the measurements. The highest-ranking channel is auto selected.
#BSS	The number of basic service sets (BSS) detected on this channel.
Minimum/Maximum RSSI for BSS	The minimum and maximum Received Signal Strength Indicator for the BSSs on this channel.
Noise Floor / dBm	The noise floor on this channel.

Load	A measure of the time the channel is occupied.
-------------	--

These measurements are combined to select a best channel for the Auto Channel selection. If a channel is ranked as 0, it is not considered suitable for auto selection. If all the channels show poor results, then moving the Veeahub to another position should be considered.

You can rescan the measurements by clicking **Rescan**. This may change the channel used.

4.7. IP Address



This screen is available only on a gateway Veeahub (MEN). Tap the IP Configuration option on the Dashboard to open the IP Configuration screen as shown in Figure 28. Each parameter is described in Table 14.

The title section shows the IP address of the Veeahub. If the Veeahub is configured as a MEN, it also shows the backhaul type.

Figure 28 – IP Address

Table 14 – IP Configuration Description

Name	Description
IP address	The external IP address of the Veeahub, and the backhaul type.
Delegated prefix	Used to assign IP addresses to Veeahub devices in the network. In the case of IPv4 operation this is a private IP prefix space. You should not need to change this value, unless the backhaul interface also has the same prefix. Changing this field will cause the MEN to reboot.
MEN mesh address	Defines the IP address of the MEN on the mesh. This should be within the delegated prefix address range. Changing this field will cause the MEN to reboot.

Name	Description
Internal prefix	Used to assign IP addresses to stations connected to the Veeahub APs while the Veeahub is not connected to a mesh.
Primary DNS server	The backhaul network interface DNS is propagated across the vMesh. If the backhaul network does not have DNS, this should be configured to point to an external DNS.
Secondary DNS server	The backhaul network interface DNS is propagated across the vMesh. If the backhaul network does not have DNS, this should be configured to point to an external DNS.

4.8. WAN Gateway



Tap the WAN Configuration option on the Dashboard to open the WAN configuration screen shown in Figure 29. The details are in Table 15.

Backhaul is the service that connects the Veeahub network to the WAN. Typically, this is an Ethernet (wired) connection or a wireless connection. A cellular connection may be used as a back-up if the main connection fails. Veeahub offers a 4G Failover service as a premium option.

A Veeahub network connects to the backhaul through a single node, designated the MEN. By default, this is the first Veeahub that was used to create the mesh.

4.8.1. WAN Configuration

This screen is applicable only to the gateway Veeahub (MEN).

Any or all of the backhaul types can be enabled or disabled, if installed on the network. On the WAN configuration screen, you can place the available connections in order, so that if one connection fails, the Veeahub will fail over to a different connection. The operational status of each backhaul type is shown.

Hold and drag the backhaul icons up/down to configure the preferred order. The backhaul type that appears at the top of the list will be preferred. If this should fail, the connection that is next in the list will be used for failover.

An option is also provided to limit the use of any backhaul for system management traffic. This is useful if the backhaul is a costly resource. For example, if you wish to reduce the cost of a cellular backhaul, enable the Restricted Backhaul setting shown in Figure 29. When this setting is enabled, the Veeahub and other Veeahub units in the same mesh communicate with the management and authentication server less frequently, typically once per-hour. This setting is for control traffic only and any application traffic is unaffected.

For the Wi-Fi backhaul, the SSID and passphrase can be entered on this screen. Check the instructions for your Wi-Fi service.

For the Cellular backhaul, the APN name, username and passphrase can be entered on this screen. Check the instructions for your cellular service.

Note. Failover is available only on a LAN configured as Routed (the default). Failover is not supported in Bridged mode (section 4.2).

Note. When you make changes to the WAN configuration and interfaces, the Veeahub Manager App may display messages warning you of potential cost implications of additional data traffic.

Figure 29 – WAN Configuration

← CANCEL APPLY

WAN Gateway

Configuration Interfaces Reserved IPs

BACKHAUL

ENABLED RESTRICTED

Ethernet

Cellular

Wifi

Tap, hold and drag to re-order backhaul priority

Wi-Fi SETTINGS

SSID
veea-gateway

PASSPHRASE
.....

CELLULAR SETTINGS



APN

APN USERNAME

APN PASSPHRASE

Table 15 – WAN Configuration Description

Name	Description
Tabs	Use these tabs to select the WAN configuration or the WAN interface (section 4.8.2) option.

Name	Description
Ethernet / Cellular / Wi-Fi	Use these options to enable/disable the backhaul connections and to enable/disable Restricted for each backhaul type.
Backhaul Wi-Fi Settings	Settings for the Wi-Fi backhaul, where installed
SSID	Enter the Wi-Fi SSID.
Passphrase	Enter the Wi-Fi passphrase.
 Eye icon	Tap to reveal the Wi-Fi passphrase.
Backhaul Cellular Settings	If you have subscribed to the 4G Failover service, tapping on this line displays a screen of technical information about this backhaul. For further information, contact Veea Support.
APN	Enter the Access Point Name (APN).
APN Username	Enter the username.
Passphrase	Enter the passphrase.
 Eye icon	Tap to reveal the cellular passphrase.

4.8.2. WAN Interfaces

This screen appears only on the gateway node (MEN).

Tap the WAN Interfaces tab to open the WAN Interfaces screen, as shown in Figure 30. The details are in Table 16.

You should configure this screen to match the LAN settings (section 4.2). If your Veeahub network is connected to an enterprise network, the necessary settings, including vLAN tags where relevant, should be obtained from your enterprise WAN administrator.

Figure 30 – WAN Interfaces

The screenshot shows the 'WAN Gateway' configuration screen. At the top, there is a navigation bar with a back arrow, 'CANCEL', and 'APPLY'. Below the navigation bar is a header with a globe icon and the text 'WAN Gateway'. There are three tabs: 'Configuration', 'Interfaces' (which is selected), and 'Reserved IPs'. The main content area is divided into two sections for WAN 1 and WAN 2. For WAN 1, there is a 'WAN ID: 1' label, a green toggle switch labeled 'Active', a 'WAN NAME' field with the value 'default', a 'VLAN TAG' field with the value '0', and a 'PORT' dropdown menu with 'Port 2' selected. For WAN 2, there is a 'WAN ID: 2' label, a grey toggle switch labeled 'Active', a 'WAN NAME' field, a 'VLAN TAG' field with the value '0', and a 'PORT' dropdown menu with 'No active port' selected.

Table 16 – WAN Interfaces Configuration Description

Name	Description
Tabs	Use these tabs to select the WAN interface or the WAN configuration option.
WAN 1 check box	Use Wide Area Network (WAN) 1.
WAN Name	Free text to identify WAN 1 interface.

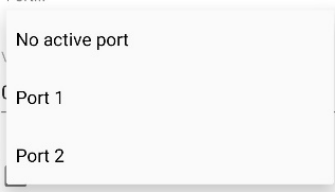
Port	Select WAN 1 port options from the drop-down menu: 
VLAN Tag	Set the VLAN tag for the WLAN interface traffic for WAN 1. A value of 0 means no tag.
WAN 2. WAN 3, WAN 4 controls	These controls, when required, use the same format and layout as WAN 1 above.

4.8.3. WAN Reserved IPs Tab

This tab (Figure 31) is used to configure a reserved (fixed) IP address for the gateway Veeahub on the WAN. This is usually necessary only when the WAN does not have a DHCP server.

The configuration options are listed in Table 17.

Figure 31 – WAN Reserved IPs

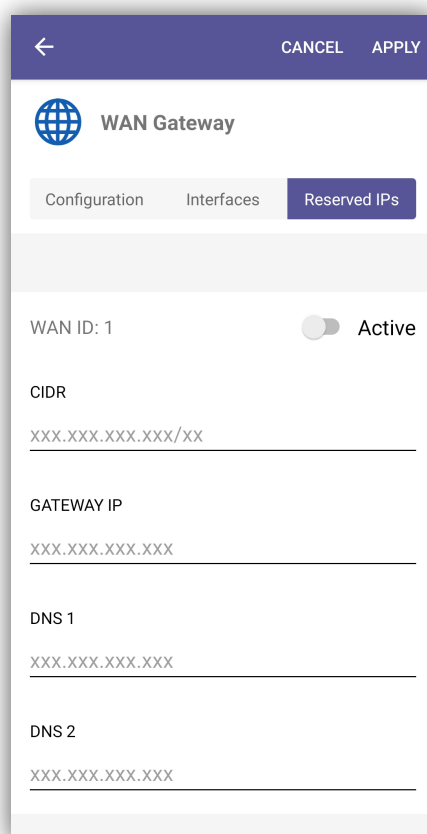

Table 17 – WAN Reserved IPs Configuration Description

Name	Description
WAN x	You can set reserved IP addresses for any of the WAN interfaces you have defined. Check the box next to the WAN number to be assigned a reserved IP address.
CIDR	Set the reserved address and subnet mask in CIDR format (###.###.###.##/#)
Gateway IP	Set the Gateway IP address.
DNS 1, DNS 2	Assign DNS nameservers.

4.9. Physical Port Configuration



Tap the Physical Ports button on the Dashboard to show more information about the Ethernet ports on the Veeahub network. The screen is shown in Figure 32 and the details are described in Table 18.

Port configuration

A port can be configured as a WAN or LAN port:

- **WAN:** this port is used as the wired connection (backhaul) to the Internet. This is available on the gateway Veeahub (MEN) only. The WAN settings are described in section 4.8.
- **LAN:** this port is in use to connect a device to the Veeahub network with an Ethernet cable. This can be applicable on any node in the network, where a port is available. Several devices can be connected to this port if you use a switch. The LAN settings are described in section 4.2.

Mesh ports

A port can also be used to create a wired connection to another Veeahub and thus to the mesh network. This might be used, for example, to bridge the gap with a cable between two nodes where the distance is too great for effective Wi-Fi communication. A Veeahub mesh can consist of any mixture of wired and wireless links. The mesh configures itself to provide full connectivity and redundancy. When a port is in use as a mesh port, this is displayed by the Mesh switch on this tab against that port.

if all the Veeahubs in the network are wired, the wireless mesh can be switched off (section 4.6.1), although that is not necessary.

There are certain cases in the current software version where some manual configuration may be needed. For more information about automatic configuration for wired mesh, please see veea.com/support

VHC05 ports

On the VHC05, there is only one Ethernet port. In the typical case of Ethernet backhaul, the Ethernet port on the MEN is already dedicated to the WAN. You can use the USB ports as Ethernet ports with suitable adaptors. In these cases, Port 2 is the lower USB socket, and Port 3 is the upper USB socket.

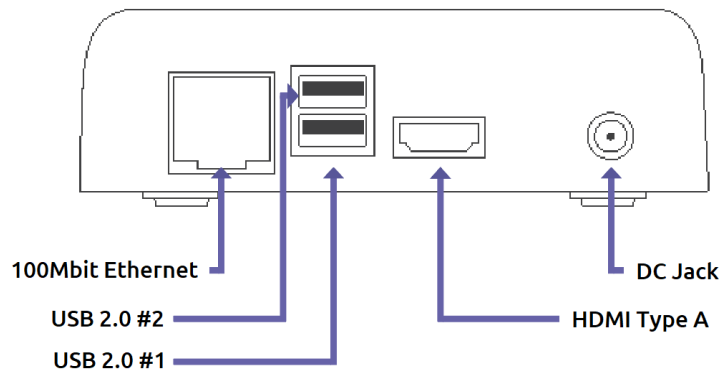

When used with an Ethernet adaptor,
USB #1 is Eth port #2 and USB #2 is Eth port #3

VHE09/VHE10 ports

On the VHE09/10, there are two Ethernet ports. They are marked on the casing with one dot for Port 1 and two dots for Port 2. Either port can be used as the WAN port, and the other can be configured as LAN. By default, Port 2 on the gateway Veeahub is configured for WAN. If you change the cable to the other port, you must restart the Veeahub. Port 1 can be used for Power over Ethernet, as an alternative to the regular power supply. Note that on the gateway Veeahub it is not possible to configure both Ethernet ports as LAN ports.

There are also two USB ports that can be used as Ethernet ports with adaptors. They are Port 3 (one dot) and Port 4 (two dots). The USB port with three dots cannot be used as a LAN port.

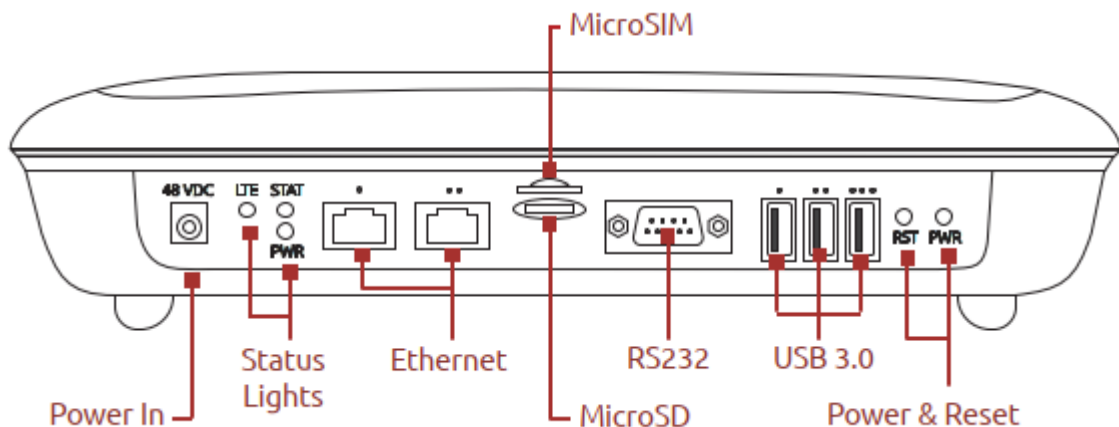

Example uses of Physical Ports configuration

An example of the use of the Port number and Enabled/Disabled controls is:

- On the gateway Veeahub, you select a Port number, select **NETWORK**, then select **Enabled**. The configuration of that port (WAN, LAN or Mesh) is then copied to all the nodes in the mesh.
- On another node, you select the same Port Number and then set to **Disabled**. This turns off the function on that port on that Veeahub. This might be used, for example, where you wish to disable the LAN port on a node in a public area so that it is not possible to plug in an unauthorized device.
- Alternatively, on the other node, you can select **HUB**, then configure the port for a specific use on that Veeahub alone.

Figure 32 – Physical Ports Configuration

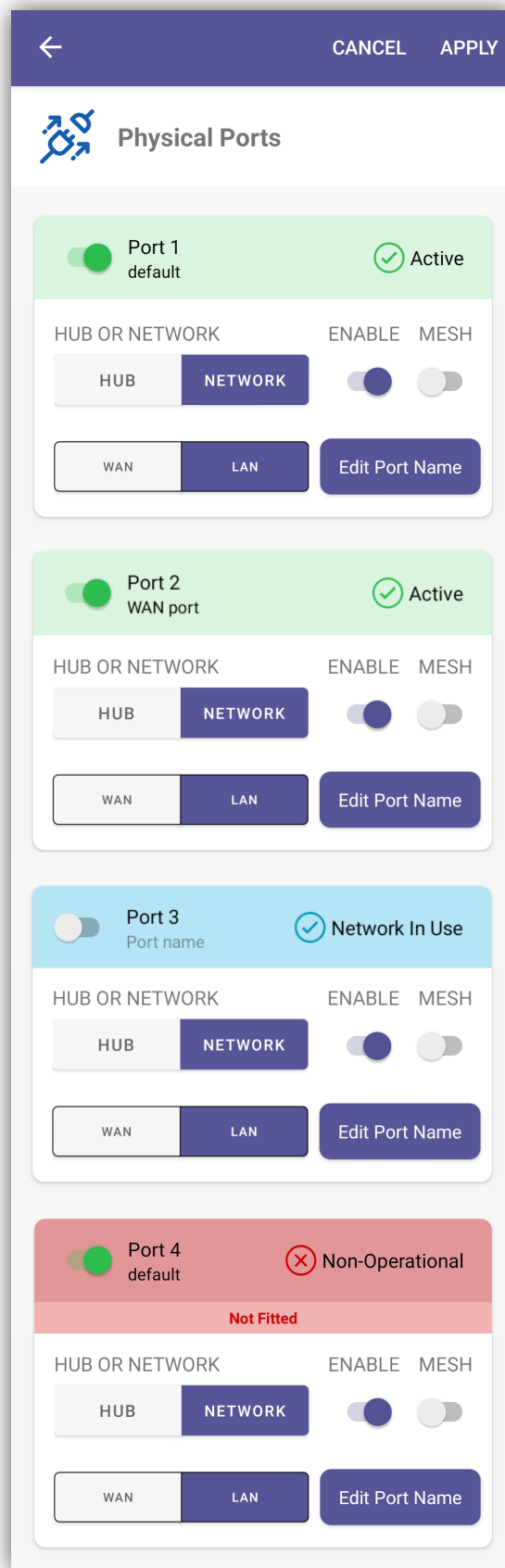
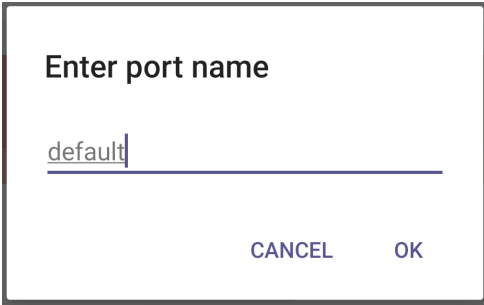

Table 18 – Physical Ports Configuration Description

Name	Description
Port 1	<p>Select this to use this node on this hub. If the Enable switch is set on, the port has the settings that are configured here. If the Enable switch is off, the port is disabled on this Veeahub, even if it is configured for the whole network (see Hub or Network, below).</p> <p>The name below the port number can be defined using the Edit Port Name option.</p>
Status	<p>At the right of the port number, the current status of this port is displayed with a symbol, for example, Active, Non-operational, Disabled, Used by Hub, Changes not applied.</p>
	<p>Below the port number, information or error messages are displayed.</p>
Hub/Network	<p>On the gateway Veeahub (MEN), set this to Network to apply the settings to port on all nodes across the Veeahub network.</p> <p>On any Veeahub, set this to Hub to apply the settings to the port on this node alone. This overrides any mesh-wide settings for this port.</p>
Enable	<p>Enables an override of the default usage of this port. For usage, see above.</p>
Mesh	<p>If on, this port is configured for wired mesh connection (see Mesh Ports, above).</p>
WAN/LAN	<p>This selects this physical port for WAN or LAN use.</p> <p>WAN: This can only be set on a gateway Veeahub and indicates which port is used for backhaul connectivity. The WAN settings are described in section 4.8. There must be only one WAN port on a mesh.</p> <p>LAN: This specifies that the port is a LAN connection for other devices.</p>
Edit Port Name	<p>Enables you to change the name of this port. Enter the new name, and tap OK.</p> 
Port 2, Port 3, Port 4	<p>This group of controls applies changes to the other ports as described above for Port 1.</p>

Icons and colors

The icon and background color of a Port entry give information about the state of the Port. For full details, see the Status message displayed.



Green

The Port is active and properly configured for this setting



Blue

The Port is configured for the network (if Hub is selected) or configured for this Veeahub (if Network is selected)



Orange

The Port is disabled



Red

The Port is non-operational



Yellow

The configuration of this Port is incomplete



No color

The Port is waiting for you to **Apply** a change in configuration

No color

The Port is not in use

Note. If an Ethernet cable is connected to another network with a DHCP server and is plugged into a LAN port, this is an error situation. VHM will display the message 'DHCP conflict'. See section 7.3.

Note. When an Ethernet port is In Use and Enabled but has no connected device, VHM will display the message 'Port Down'.

Note. If a USB port has been configured as a LAN port but no Ethernet adaptor is present, the message 'Not Fitted' is displayed.

Note. These messages are displayed if the error condition applies when you connect VHM to the Veeahub, or if you tap APPLY while on the Physical Port screen.

4.10. Cellular Usage Analytics



These statistics are available on gateway Veeahubs enabled for 4G backhaul (section 4.8).

Tap the Cellular Stats option on the Dashboard. The Cellular Stats screen is shown in Figure 33.

Figure 33 – Cellular Stats

Cellular Usage Analytics	
IMEI	866758045528060
ICCID	89852201904102524483
Network mode	4G
RSRQ	14dB-
RSRP	101-
RSSI	67-
SINR	19dB-
EARFCN	1617
Bandwidth Up	20MHz
Bandwidth Down	20MHz
Network Operator	EE iFREE
Srxlev	-
Tracking Area Code	2B23
LTE Driver v.	Quectel_Linux&Android_GobiNet_Driver_V1.6.1
LTE Firmware v.	EC25EFAR06A08M4G_01.007.01.007
Product LTE Backhaul	Quectel EC25E
Sim Status	Inserted [CPIN READY + SMS DONE + PB DONE]
Network Registration Status	Registered. Roaming

Tap **DONE** to return to the Dashboard.

4.11. Firewall Configuration

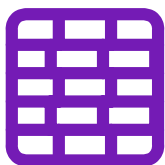

Tap the Firewall Configuration option on the Dashboard to configure Firewall rules. The screen (Figure 34) allows configuration of firewall rules. Any rules already configured are displayed on this screen on two tabs, ACCEPT/DROP RULES and FORWARD RULES.

Figure 34 – Firewall configuration

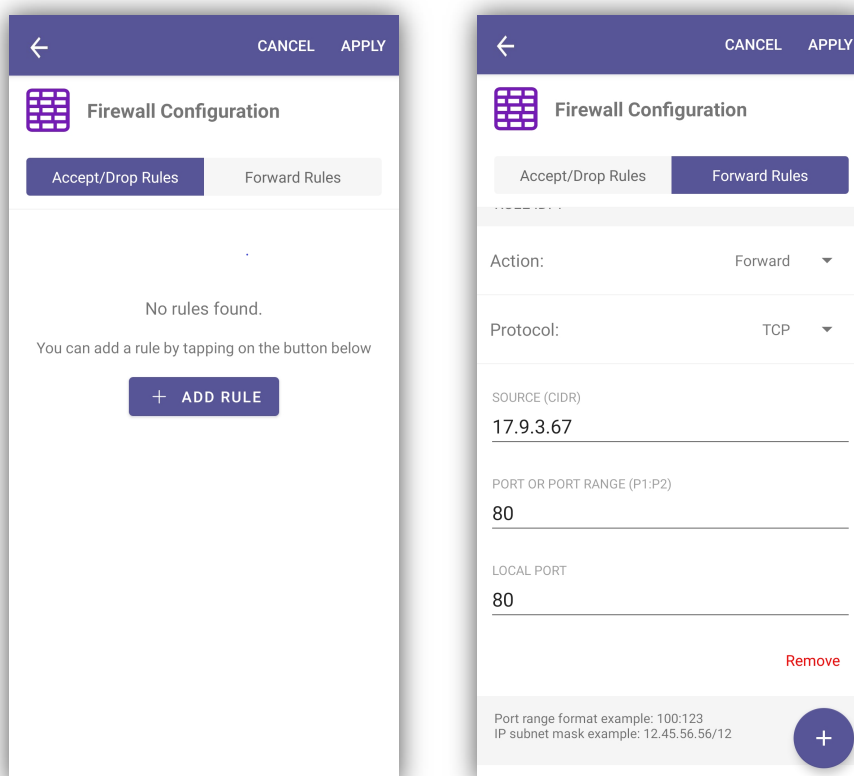

4.11.1. Creating a New Rule

To set up a new rule (Figure 34):

1. If no rules are displayed, tap the **+ ADD RULE** button, or if rules are already displayed, tap the plus  icon to create a new rule.
2. Select the type of rule to create: **Accept, Drop or Forward**.
3. Select the protocol for the rule, **TCP or UDP**.
4. Enter the data specific for the rule.
5. Tap **Create**.

For specific details, see section 4.11.2 for Accept and Drop rules, and section 4.11.3 for Forward rules.

For deleting rules, see section 4.11.4.

4.11.2. Creating a New Accept/Drop Rule

Figure 35 – New Accept or Drop Rule

The screenshot shows a mobile application interface for configuring a firewall rule. The background is a 'Firewall' configuration screen with a grid icon and a 'Firewall' title. A modal dialog titled 'Create New Rule' is open in the center. The dialog has a dark blue header with a back arrow on the left and 'CANCEL' and 'APPLY' buttons on the right. Below the title, there are three sections: 'ACTIONS' with three buttons ('ACCEPT', 'DROP', 'FORWARD'), 'PROTOCOL' with two buttons ('TCP', 'UDP'), and two text input fields labeled 'SOURCE IP ADDRESS' and 'PORT OR PORT RANGE (P1:P2)'. At the bottom of the dialog are 'CANCEL' and 'CREATE' buttons.

Table 19 – Accept and Drop Rules Configuration

Name	Description
Actions	Select Accept or Drop .
Protocol	Select TCP or UDP .
Source IP Address	Enter the IP address to be accepted or dropped.
Port or Port Range	Enter the Port or Port Range. A Port range is entered as <i>P1:P2</i> , where P1 is the first port number in the range and P2 is the last port number.

4.11.3. Creating a New Firewall Forward Rule

Figure 36 – New Forward Rule

The screenshot shows a mobile application interface for configuring a firewall rule. At the top, there is a navigation bar with a back arrow, 'CANCEL', and 'APPLY' buttons. Below this is a 'Firewall' header with a grid icon. The main content is a 'Create New Rule' dialog box. Inside the dialog, there are three sections: 'ACTIONS' with buttons for 'ACCEPT', 'DROP', and 'FORWARD' (selected); 'PROTOCOL' with buttons for 'TCP' (selected) and 'UDP'; and three text input fields labeled 'SOURCE IP ADDRESS', 'PORT OR PORT RANGE (P1:P2)', and 'LOCAL PORT'. At the bottom of the dialog are 'CANCEL' and 'CREATE' buttons.

Table 20 – Forward Rules Configuration

Name	Description
Actions	Select Forward .
Protocol	Select TCP or UDP .
Port or Port Range	Enter the Port or Port Range. A Port range is entered as <i>P1:P2</i> , where P1 is the first port number in the range and P2 is the last port number.
Source IP Address	Enter the IP address to be forwarded.
Local Port	Enter the Local Port to be forwarded to.

4.11.4. Deleting a Firewall Rule

To delete a firewall rule, tap **Remove** against the rule.

4.12. Services



This option (Figure 37) opens a list of optional services and software that you have installed. To view information and configuration options for one of these, tap on its name in the list.

Figure 37 – Services

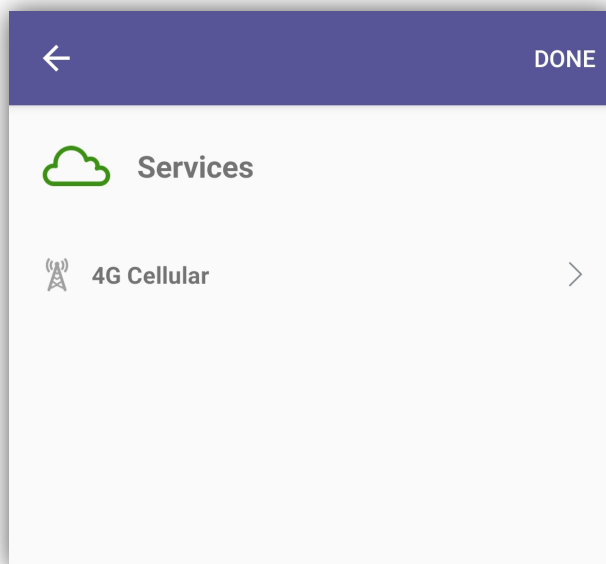

4.13. Bluetooth Beacon Configuration



Tap the Beacon option on the Dashboard to open the Beacon Configuration screen shown in Figure 38. The details are in Table 21.

The Bluetooth beacon on a Veeahub broadcasts an advertisement consisting of a sub-domain and Instance ID. These details are configured when the Veeahub is added to your account. This screen is for information only.

Figure 38 – Beacon Configuration

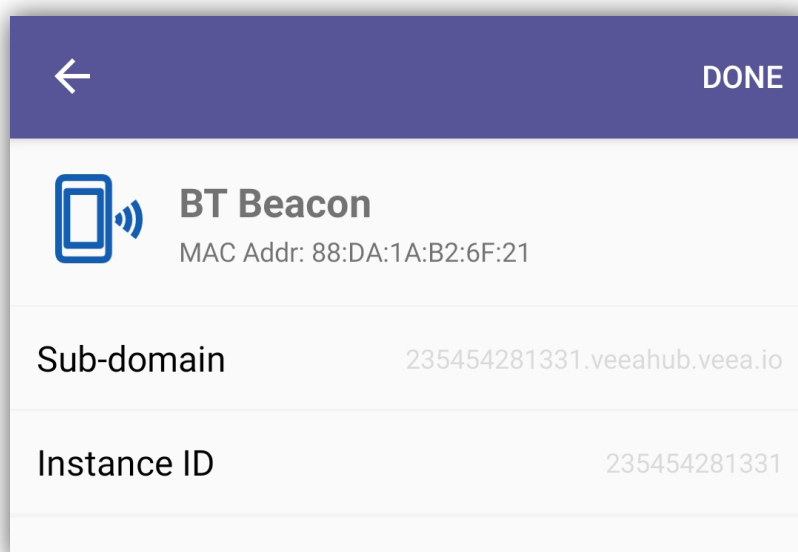

Table 21 – Beacon Configuration Description

Name	Description
Screen title	Includes the MAC address
Sub-domain	Sub-domain name
Instance ID	The instance ID number

4.14. About Veeahub



Tap the About Veeahub option on the Dashboard to open the About Veeahub configuration screen shown in Figure 39. The details are in Table 22.

The first Veeahub in a network has the status of gateway node (also called MEN), and connects the mesh to the Internet. Further Veeahubs are edge nodes (also called MN).

The Node Name is set when the Veeahub is added to your account. You can change it on this screen.

Position is an optional text field. You can use it for any descriptive purpose, for example, to show where the Veeahub is located on your premises.

Figure 39 – Veeahub Configuration

The screenshot shows the 'About Veeahub' configuration screen for a Veeahub with ID VH-0511. The screen is divided into several sections:

- TIME AND LOCATION:**
 - Hub Time: 2021-04-21 12:44:20
 - Hub Location: London, GB
 - Tap hub time to refresh
- SETTINGS:**
 - Node name (eg. VH-1314): **VH-0511**
 - Position (e.g. 1st floor):
 - Node type: **MEN** (dropdown menu)
 - Settings are applied when you tap Apply
- INFORMATION:**
 - Software version: 2.17.0-2
 - OS version: 4.9.0
 - Restarted: 2021-04-19 12:59:22
 - Restart reason: CPU. Shutdown
 - Restart required: **No restart needed** (green text)
 - Hardware version: 1.0
 - Hardware revision: B
 - Unit serial: E09BCW00C0B000000511

Table 22 – Veeahub Configuration Description

Name	Description
Screen name	The screen name also shows the node name and the serial number of the Veeahub.
TIME AND LOCATION	
Hub Time	Tap this line to refresh the time display.
Hub Location	The city and country this Veeahub is registered to.
SETTINGS	
Node Name	Tap on the row to customize the node name.
Position	This may be empty. The locale is free text that can be used to identify the Veeahub, for example, by its location in a building.
Node type	<p>MEN (Mesh Edge Node, gateway node) or MN (Mesh Node, network node). An MN connects to the wider internet via the MEN.</p> <p>A MEN acts as a gateway for the mesh and has a number of connection options to the wider internet, including cellular, Ethernet and Wi-Fi backhaul. For a MEN, these options are configured by tapping on the WAN option, Figure 15, detailed in section 4.8.</p> <p>If the node type is changed, the node must be rebooted. The mesh SSID automatically reverts to the default and can be changed to enable the Veeahub to join the intended network.</p>
INFORMATION	
Software version	The version of the Veeahub software.
OS version	Operating System (OS) version.
Restarted	The time the Veeahub was last restarted.
Restart Reason	The reason why the Veeahub was last restarted.
Restart Required	Whether the Veeahub currently requires a restart.
Hardware version	The version of the Veeahub hardware.
Hardware revision	The revision number of the hardware version.
Unit Serial	Serial number of this Veeahub.

4.15. Shutdown, Restart or Recover



Tap the Shutdown, Restart or Recover option on the Dashboard. This opens the Power Controls dialog as shown in Figure 40.

Figure 40 – Power / Reboot

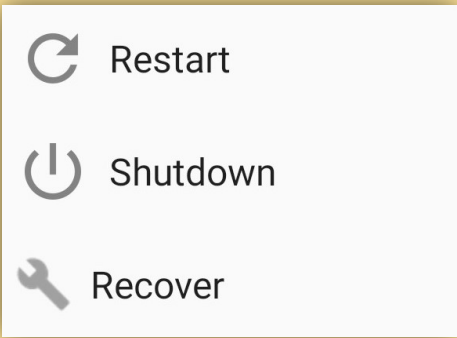
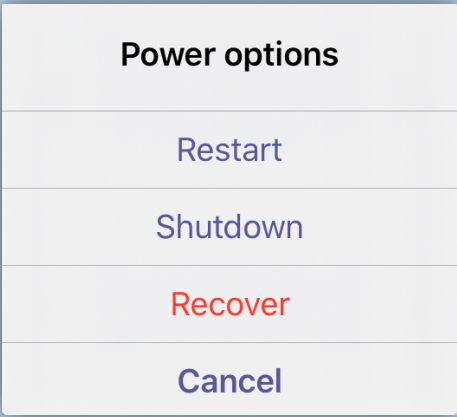
<p>Android</p>	 <p>To cancel, tap on the screen outside the box.</p>
<p>Apple</p>	 <p>To cancel, tap on Cancel.</p>

Available power control functions are:

- **Restart:** restart the Veeahub
- **Shutdown:** shut down the Veeahub
- **Recover:** the Veeahub will do a recovery or reinstall of the software. See Figure 41.

Recover: The Veeahub is restored by downloading software and configuration from the cloud. All the existing configuration information is wiped, and the Veeahub is restored as if it had been added for the first time. Any local updates made since the Veeahub was first added may be lost.

- Tap **Begin Recovery** to initiate the Recovery procedure.

Reinstall: The Veeahub is restored by reinstalling from software and configuration maintained on the unit. Configuration settings are changed to settings at the time when the Veeahub was added to your account, and any local updates made after that may be lost.

- Tap **Reinstall System** to initiate the Reinstall procedure.

Figure 41 – Recovery and Reinstall

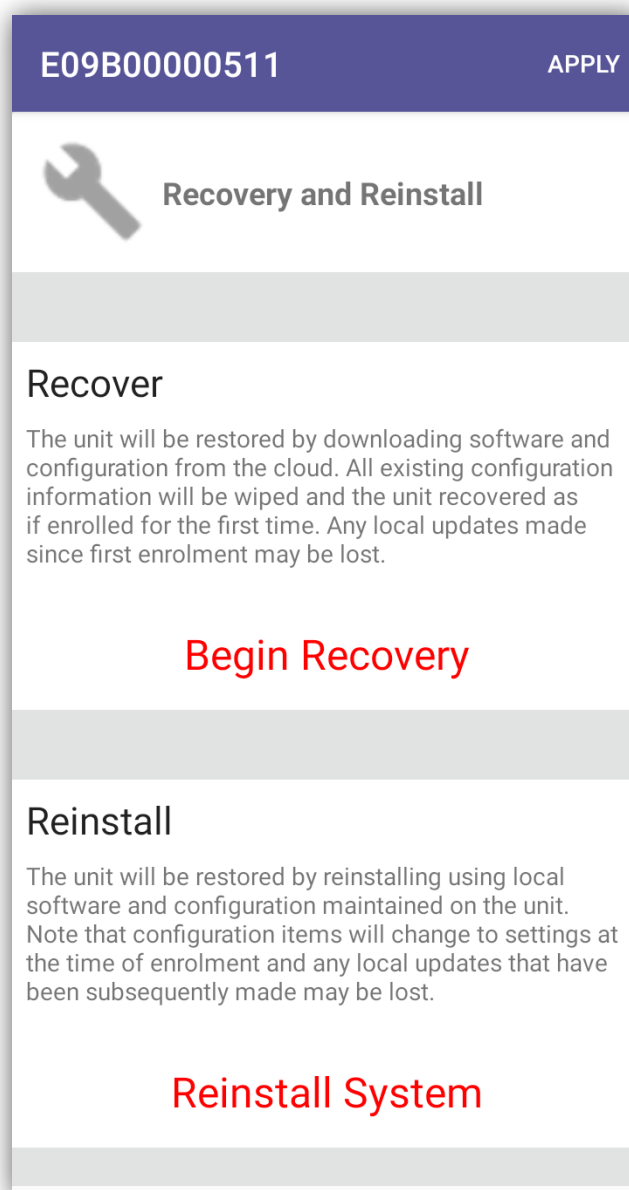

5. Removing a Veeahub from your Account

You can remove a Veeahub from your account using Veeahub Manager.

This enables the Veeahub to be added under a different account or for its role to be changed from gateway node (MEN) to edge node (MN).

1. Log in to Veeahub Manager.
2. Tap the Veeahubs icon on the Home screen (Figure 9).



3. Select the network from My Meshes (Figure 6).
4. From the listed Veeahubs, select the node you wish to remove (Figure 7).
5. On the Dashboard (Figure 15), tap **Remove Veeahub**.

You are prompted to confirm this:

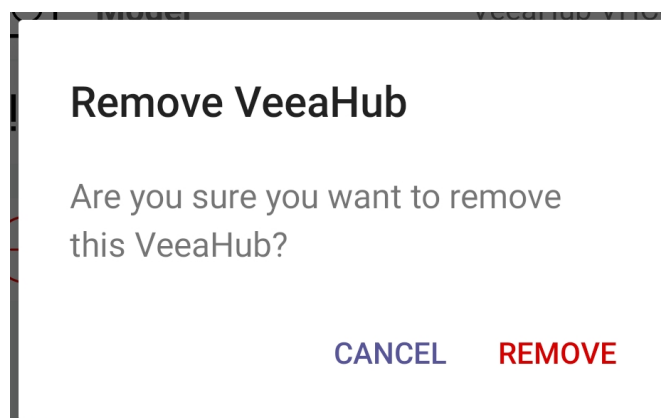

Note. Before you can remove a gateway Veeahub (MEN) from a mesh, you must either remove the other nodes, or assign as gateway another Veeahub in the mesh (section 4.14).

Note. You must also remove any packages that have been installed on the Veeahub.

6. LAN Configuration

6.1. Default Configuration

When a Veeahub is enrolled as the first unit in the network, it automatically becomes the gateway Veeahub, which also has management functions on the network. The LAN is established with the defaults in the table below, using the gateway option above. These settings can be changed using the relevant screens in Veeahub Manager or Enterprise Center.

LAN Attribute	Notes
WAN Interface	The WAN interface used for the LAN is the interface that is connected to the Internet when the Veeahub is enrolled.
Mode	Routed (NAT)
Internal DHCP	Enabled
Wi-Fi Access Points	First Wi-Fi entry for 2.4GHz and 5GHz. See below.
Ethernet Ports	All ports (other than the Gateway WAN interface) are configured as LAN by default, on the single subnet.
DNS Lease Time (minutes)	60
Default LAN	10.100.1.0/24
Guest Wi-Fi	10.100.2.0/24
Public Wi-Fi	10.100.5.0/24
LAN 3	10.100.3.0/24 - optional reserved
LAN 4	10.100.4.0/24 - optional reserved
Layer 3 Mesh (internal use)	10.101.0.0/16
Layer 3 Local (internal use)	10.102.0.0/16 (mesh internal prefix)
Docker	172.17.0.0/24
	172.18.0.0/24
LoRaWAN	169.254.0.0/16
Privafy	
<future>	

The port used for WAN connection is configured on power up. The physical connection can be changed, then the hub can be restarted.

The default for the first Wi-Fi entry is an SSID that matches the mesh name chosen when the first Veeahub on the network is enrolled. For example, if the mesh name given during enrollment is 'MyNetwork', the first user SSID is also 'MyNetwork'. The mesh name can be changed in the vMesh Configuration screen of Veeahub Manager, or the network name in the Network Configuration tab of Enterprise Center.

This SSID is configured across the Veeahub network, so any other Veeahubs in the same network also have a Wi-Fi access point with a 'MyNetwork' SSID, for both the 2.4GHz radio and 5GHz radio.

Note: On a VHE09/10, the 5GHz AP is enabled by default. On a VHC05, the 5GHz AP can only be enabled if the wireless mesh used to connect peer Veeahubs is first disabled.

Note: Failover is available only on a LAN configured as Routed (the default). Failover is not supported in Bridged mode.

6.2. IP Conflict Resolution

The Veeahub platform uses specific IP ranges for internal purposes. These default LAN and guest and public Wi-Fi ranges can be manually configured, if required for specific purposes.

In the event that the gateway hub detects a conflict with the IP addresses on the WAN it can switch automatically to the alternate IP ranges listed below.

Subnet	Alias	Principal	Alternate
Default LAN	shared:trusted	10.100.1.0/24	172.20.1.0/24
Guest Wi-Fi	shared:guest	10.100.2.0/24	172.20.2.0/24
Public Wi-Fi	Shared:public	10.100.5.0/24	172.20.5.0/24
L3 standard		10.101.0.0/16	172.21.0.0/16
L3 alternate		10.102.0.0/16	172.22.0.0/16

A LAN is switched to its alternate subnet if a WAN interface for the LAN is in conflict, and the subnet has been automatically assigned.

If the subnet has been manually assigned, and a WAN interface is in conflict, the LAN is marked as non-operational. If a LAN is non-operational, this is reported in Node Manager and in Veeahub Manager.

7. Troubleshooting

7.1. Failed Adding the Veeahub

If the process fails while you are adding the Veeahub to your account (section 2.2), an error message appears showing the stage at which the failure occurred (Figure 42).

Figure 42 – Example Error Screen

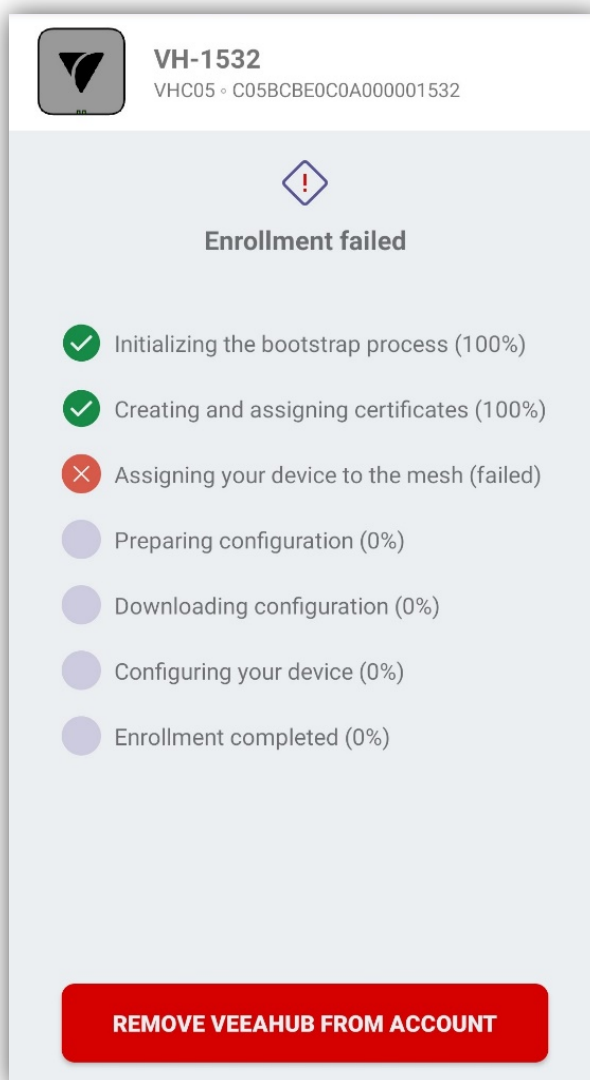

Click on the **Remove Veeahub from Account** button to start the process again.

7.2. Difficulty connecting to your Veeahub using Veeahub Manager

If you are having problems connecting to your Veeahub, here are some possible solutions.

- **Make sure that you are close enough to the Veeahub**

If VHM does not connect, this may be caused by wireless interference. Try moving your mobile device closer to the Veeahub. If this happens repeatedly, the next time you have a connection set the 2.4GHz channel to another value that may be less prone to interference (see section 4.1.2).

- **Make sure that your Location setting is enabled**

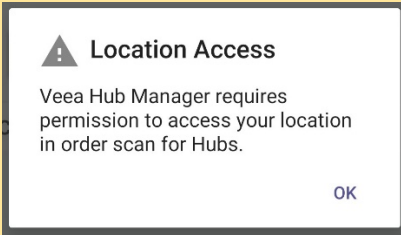
Android	<p>On first login, or if the permission is lost, Veeahub Manager will display a warning message that you must acknowledge by tapping OK.</p> <div style="text-align: center;">  </div> <p>The operating system will prompt you for your permission.</p>
----------------	--

- **Make sure that you do not have a Virtual Private Network (VPN) running on your mobile device.**

A VPN makes it impossible for the device to connect to the Veeahub.

- **Go back to the My Meshes screen before trying again.**

7.3. DHCP Conflict

If the message 'DHCP conflict' is displayed on the Physical Ports configuration screen against an Ethernet port configured as LAN, this means that another DHCP server has been detected on the LAN. This is an error situation. The Veeahub will automatically isolate this connectivity until resolved as follows:

- First, you must resolve the error by removing the DHCP server. This may require intervention by the network administration. Or if the cable has been connected incorrectly, reconnect it in correct configuration.
- To subsequently clear the error status, disable and re-enable the port, or remove the cable from the port and reconnect it.

7.4. Configuration of VHE09 as MEN in Mixed 09/10 Configurations

When a VHE09 gateway Veeahub (MEN) is wirelessly meshed with a VHE10 non-gateway Veeahub (MN), this can impact the VHE10 (MN) ability to connect wirelessly to the VHE09 (MEN).

This happens when the VHE09 (MEN) 5GHz channel selection is set to automatic. In this case, the 5GHz channel is determined automatically by the Veeahub software. Regulated 5GHz channel allocations vary from country to country. Some configurations of VHE09 units, for example, the US, have an extended channel capability with both low and high band channels available, whereas the VHE10 units, default to low band channels for wireless meshing. If the automatic channel selection on the VHE09 (MEN) selects a channel above 100, the VHE10 (MN) unit will not see the channel when it scans and cannot connect.

Solution:

Restrict the VHE09 (MEN) high band channels available for use by the automatic channel selection. This is implemented by use of the 'Auto Channel Whitelist' control as follows:

1. Login to the Veeahub Manager account which contains the VHE09 (MEN) unit in focus.
2. Navigate to the VHE09 (MEN) vMesh configuration screen (Figure 43):
 - From the VHM, Select the required mesh
 - Select the required Veeahub (MEN)
 - Tap the vMesh icon
 - Select the Auto Channel Whitelist (A popup box of channels will appear) as shown in Figure 44
 - For each channel 100 and above, Deselect/Untick each one
 - Select **OK** to save the setting
 - Confirm the configuration change has resolved the connection issue
 - Procedure completed.

Note. The configuration changes described above can also be implemented from the Node Manager (NM). Refer to the NM Guide which describes the alternative procedure.

Figure 43 – vMesh Screen (Example)

The screenshot displays the vMesh configuration interface. At the top, there is a back arrow and an 'APPLY' button. Below the vMesh icon and title, there is a 'More about this page' link. The configuration fields are as follows:

- Mesh Name:** E09BCWE0C0B000000605-vmesh
- SSID:** VMESH-0605
- Password:** [Redacted]
- WLAN Enabled (Wired Hubs):** [Enabled]
- WLAN Operation (Local Hub):** Start network
- Channel:** Auto Selection
- Channel In Use:** 44
- Exclude DFS:** [Enabled]
- Auto Channel Whitelist:** 36, 40, 44, 48
- Wi-Fi Network Scan:** [Scan]
- Bandwidth:** 20/40
- Bandwidth In Use:** 40
- Transmit Power (%):** 100

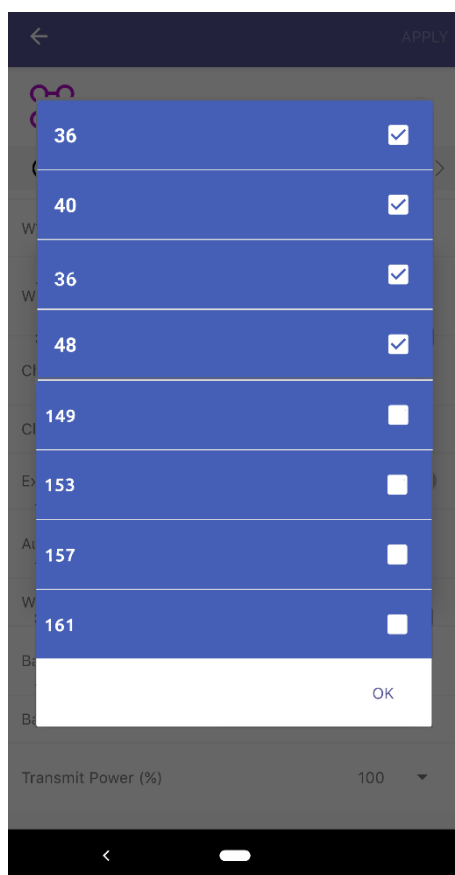
Figure 44 – vMesh Auto Channel Whitelist (Example Popup Box Screen)

8. Technical Support

Before contacting Technical Support, please consult the documentation, tutorials, and community topics available on the support web site www.veea.com/support/. Please sign up, if you don't already have an account, and sign in.

For unresolved queries, click on the Submit a request link located near the top of the screen.

Please complete the form with an appropriate subject, and as much detail as possible in the description field. Please include any relevant information such as Veea hardware serial numbers, logs, and screenshots.

An email will automatically be sent to your registered email address to confirm the request has been received.